

Scope

These operating instructions are valid for all read heads/actuators CMS for safety relays ESM. These operating instructions, the operating instructions for safety relays ESM-BA2.. and ESM-BA3.., the document *Safety information* and any available data sheet form the complete user information for your device.

Important!

Make sure to use the operating instructions valid for your product version. The version numbers can be found on the type label of your product. Please contact the EUCHNER service team if you have any questions.

Read head type label

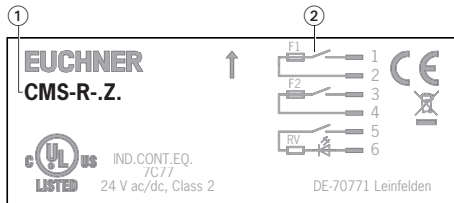

- ① Item designation
- ② Circuit diagram

Supplementary documents

The overall documentation for this device consists of the following documents:

Document title (document number)	Contents	
Safety information (2525460)	Basic safety information	
Operating instructions (2096881)	(this document)	
Operating instructions (2090071)	Basic module ESM-BA2..	
Operating instructions (2090073)	Basic module ESM-BA3..	
Declaration of conformity	Declaration of conformity	
Any additions to the operating instructions	Take any associated additions to the operating instructions or data sheets into account.	

Important!

Always read all documents to gain a complete overview of safe installation, setup and use of the device. The documents can be downloaded from www.euchner.com. For this purpose, enter the doc. no. or the order number for the device in the search box.

Correct use

In combination with safety relays ESM-BA2.. and ESM-BA3.., the Coded Magnetic read heads and actuators of series CMS are safety devices for monitoring movable guards.

To use the read heads CMS-R-AZA..., CMS-R-AZC..., CMS-R-BZB... and CMS-R-BZD... in category 4 with Performance Level e according to EN ISO 13849-1, evaluation must be performed using the related EUCHNER safety relays ESM.

The system consists of evaluation unit, read head and actuator. It forms a non-contact, magnetically coded interlocking device with low coding level (type 4).

In combination with a guard, this system prevents dangerous machine functions from being performed for as long as the guard is opened. A stop command is triggered if the guard is opened during the dangerous machine function.

Before safety components are used, a risk assessment must be performed on the machine, e.g. in accordance with:

- ▶ EN ISO 13849-1
- ▶ EN ISO 12100
- ▶ EN IEC 62061

Correct use includes observing the relevant requirements for installation and operation, e.g.:

- ▶ EN ISO 14119
- ▶ EN IEC 60204-1

Important!

- ▶ The read heads and actuators must be used only with the designated evaluation units from EUCHNER. On the use of different evaluation units, EUCHNER provides no warranty for safe function.
- ▶ The user is responsible for safe integration of the device into a safe overall system. For this purpose, the overall system must be validated, e.g. in accordance with EN ISO 13849-1.
- ▶ Correct use requires observing the permissible operating parameters (see technical data).
- ▶ If a data sheet is included with the product, the information on the data sheet applies in case of discrepancies with the operating instructions.
- ▶ Only components that are permissible in accordance with the following *combination options* table may be used. Refer to the operating instructions of the corresponding component for further information.

Exclusion of liability and warranty

In case of failure to comply with the conditions for correct use stated above, or if the safety regulations are not followed, or if any servicing is not performed as required, liability will be excluded and the warranty void.

General safety precautions

Safety components fulfill personnel protection functions. Incorrect installation or tampering can lead to severe injuries to personnel.

Check the safe function of the guard particularly

- ▶ after any setup work
- ▶ each time after replacement of a CMS component
- ▶ after an extended period without use
- ▶ after every fault

Independent of these checks, the safe function of the safeguard should be checked at suitable intervals as part of the maintenance schedule.

Warning! Danger of fatal injury in the event of incorrect connection or incorrect use.

Safety components must not be bypassed (bridging of contacts), turned away, removed or otherwise rendered ineffective. Pay particular attention to EN ISO 14119: 2025, section 8, regarding the possibilities for bypassing an interlocking device.

The device may be installed and put into operation only by authorized personnel

- ▶ who are familiar with the correct handling of safety components
- ▶ who are familiar with the applicable EMC regulations
- ▶ who are familiar with the applicable regulations on operational safety and accident prevention
- ▶ who have read and understood the operating instructions.

Function

The CMS consists of a read head and actuator and is functional only in specific combinations (see combination options).

The read head connected to the evaluation unit contains reed contacts that are activated by the coded magnetic actuator. The evaluation unit converts this information and transfers the guard state to the control system.

Mounting

Caution! Risk of damage to equipment as a result of incorrect installation.

Read heads or actuators must not be used as a mechanical end stop. Fit an additional end stop for the movable part of the guard.

Caution! Read heads or actuators must not be used in an environment with strong magnetic fields.

Important! Read heads and actuators must be positively mounted to the guard, e.g. by using the safety screws supplied. Tighten the screws with a torque of max. 0.5 Nm.

Important! The M8 plug connector must be tightened with a suitable tool.

The read head and actuator may be installed in any position. The alignment of the read head and the actuator must be kept in mind (see Fig. 1).

Install read head and actuator so that:

- ▶ they are accessible for inspection work and the installation of spare parts
- ▶ when the guard is closed, the active read head and actuator faces are exactly aligned (see Fig. 1)
- ▶ the actuator is located in the read head's actuating range when the guard is closed.

▶ A guide and an additional end stop must be fitted for the movable part of the guard.

▶ A latching mechanism in the closed position must be provided for the safety door.

▶ If the read head and actuator are installed flush, the operating distances are reduced in line with the installation depth and the guard material.

▶ If the read head and actuator are mounted on ferromagnetic material, the read distance is reduced.

▶ If the approach speed between the read head and the actuator is low, the approach direction **Z** (see Fig. 1) should be avoided.

Electrical connection

Warning! In the event of a fault, loss of the safety function due to incorrect connection.

Both switching contacts on the read head must be evaluated separately.

The evaluation unit must perform the short circuit monitoring on the read head connected.

Lay the connecting cables with protection to prevent the risk of short circuits.

Caution! Risk of damage to equipment or malfunctions as a result of incorrect connection.

On read heads with LEDs the current on the contact status indication is not allowed to be greater than 20 mA.

The read heads must be connected to the evaluation units in accordance with the wiring diagram (see operating instructions for evaluation units).

Service and inspection

Remove iron swarf from the read head and actuator **at regular intervals**.

Use only solvent-free cleaning agents for cleaning the actuators and read heads.

Regular inspection of the following is necessary to ensure trouble-free long-term operation:

- ▶ Correct switching function
- ▶ Secure mounting of components
- ▶ loose connections.

⚠ In the event of damage or wear, the damaged system component must be replaced.

Exclusion of liability under the following circumstances:

- › Incorrect use
- › Non-compliance with safety regulations
- › Installation and electrical connection not performed by authorized personnel
- › failure to perform functional checks.

Notes about UL

This device is intended to be used with a Class 2 power source in accordance with UL1310.

As an alternative an LV/C (Limited Voltage/Current) power source with the following properties can be used:

This device shall be used with a suitable isolating source in conjunction with a fuse in accordance with UL248. This fuse shall be rated for max. 5 A and for a secondary voltage between 0 V and 20 V with direct current (0 V - 28.3 V peak with alternating current), or the power in the secondary circuit must not exceed 100 VA at a secondary voltage of 20 V - 30 V with direct current (28.3 V - 42.4 V peak with alternating current) to comply with the UL requirements. Please note the connection ratings for your device (refer to the technical data).

Declaration of conformity

The product complies with the requirements according to

- › Machinery Directive 2006/42/EC (until January 19, 2027)
- › Machinery Regulation (EU) 2023/1230 (from January 20, 2027)

The EU declaration of conformity can be found at www.euchner.com. Enter the order number of your device in the search box. The document is available under [Downloads](#).

Service

If servicing is required, please contact:

EUCHNER GmbH + Co. KG
Kohlhammerstraße 16
70771 Leinfelden-Echterdingen

Service telephone:
+49 711 7597-500

E-mail:
support@euchner.de

Internet:
www.euchner.com

Technical data

Parameter	Value
Read heads	
Housing material	Fiberglass reinforced PPS
Ambient temperature	-20 ... +60 °C
Ambient temperature Only CMS-R-BZD...	-20 ... +80 °C
Degree of protection	IP67
Installation position	Any, alignment with actuator should be kept in mind (markings)
Connection	Molded cable with cable end sleeves/plug connector M8, 4-pin/ molded cable with plug connector M12, 8-pin
Switching voltage	35 V DC
Switching current I_e max.	0.1 A
Built-in fuse	100 mA (per safety contact)
Rated conditional short-circuit current ¹⁾	100 A
Contact status indication (only CMS-R-AZA)	
Switching voltage	35 V DC
Switching current I_e max.	0.02 A
Monitoring contact (only CMS-R-BZD)	
Switching voltage	35 V DC
Switching current I_e max.	0.1 A
Switching frequency f_{max} at I_{min} 10 mA ¹⁾	5 Hz
Switching frequency f_{max} at nominal current 8 A ¹⁾	0.1 Hz
Switching delay from state change ^{1) 2)}	26 ms
Method of operation	Magnetic, reed contact
Mechanical life	100 x 10 ⁶ operating cycles
Shock and vibration resistance	Acc. to EN IEC 60947-5-3
EMC compliance	Acc. to EN IEC 60947-5-3
Center offset m from actuator	± 2.5 mm at distance s = 3 mm
Operating distance s_{ao}	See combination options table
Release distance s_{ar}	
Switching contacts	
Classification	
CMS-R-BZB.../CMS-R-BZD...	M3D36AS1
CMS-R-AZA.../CMS-R-AZC...	M3D88AS1
Fusing of the power supply and the safety contacts	
External contact fuse ¹⁾	Fuse 10 A gG
Actuator	
Housing material	Fiberglass reinforced PPS
Ambient temperature	-20 ... +60 °C
Ambient temperature Only CMS-M-BH	-20 ... +80 °C
Degree of protection	IP67
Installation position	Any, alignment with read head should be kept in mind (markings)
Method of operation	Magnetic
Shock and vibration resistance	Acc. to EN IEC 60947-5-3
Center offset m from read head	± 2.5 mm at distance s = 3 mm
Operating distance s_{ao}	See combination options table
Release distance s_{ar}	
Characteristics acc. to EN ISO 13849-1	
Category ¹⁾	4
Mission time	20 years
Performance Level ¹⁾	e
B_{10D}	20 x 10 ⁶ operating cycles

1) Parameter dependent on the evaluation units ESM-BA2.. and ESM-BA3.

2) Corresponds to the risk time according to EN 60947-5-3. This is the maximum OFF time for the safety outputs following removal of the actuator.

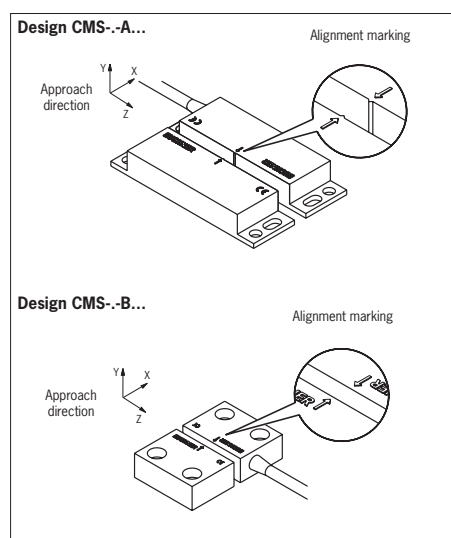

Fig. 1: Alignment of read head and actuator

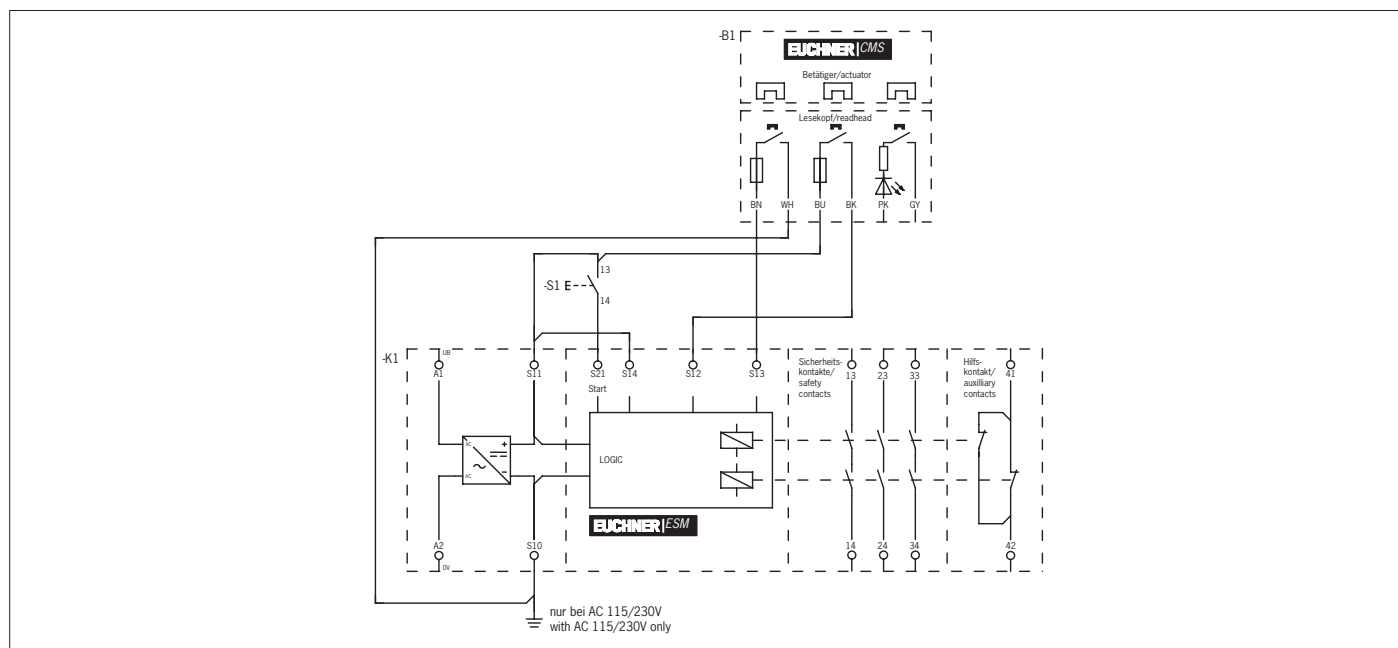

Fig. 2: Connection example consisting of ESM-BA3.., CMS-R-AZA... and CMS-M-AI

Combination options for evaluation units ESM-BA2.. and ESM-BA3.

Design	Read head	Circuit diagram, not actuated ¹⁾	Actuator	Assured operating distance s_{ao} ²⁾ [mm]	Assured release distance s_{ar} [mm]
ESM-BA3..	CMS-R-AZA		CMS-M-AI	9 (7) ⁴⁾	20 (15) ⁴⁾
	CMS-R-AZA-ST0,2VL		CMS-M-AI	9 (7) ⁴⁾	20 (15) ⁴⁾
	CMS-R-AZC-SC		CMS-M-AI	9	22
ESM-BA2..	CMS-R-BZB CMS-R-BZB-SC		CMS-M-BH	7	20
	CMS-R-BZD		CMS-M-BH	7 (6) ⁵⁾	20 (20) ⁵⁾
	CMS-R-BZD-ST0,2V		CMS-M-BH	7 (6) ⁵⁾	20 (20) ⁵⁾

- 1) Old conductor coloring in brackets.
- 2) There must be no ferromagnetic material in the vicinity of the read head or the actuator. All data refer to the frontal approach direction and a center offset of $m = 0$.
- 3) The LED for the contact status indication has an internal series resistor of 1.5 kΩ.
- 4) Operating distance for contact status indication and LED.
- 5) Operating distance for the monitoring contact.

Connection table

Connection terminals Evaluation units ESM-BA2../ESM-BA3..	Read head connections		
	CMS-R-AZA...	CMS-R-AZC...	CMS-R-BZB.../CMS-R-BZD...
S10	WH	2	WH / 2
S11 / S14	BU (GN)	3	BU (GN) / 3
S12	BK (YE)	4	BK (YE) / 4
S13	BN	1	BN / 1

Explanation of conductor coloring

Designation according to DIN IEC 60757	English	German
BK	black	schwarz
BN	brown	braun
YE	yellow	gelb
GN	green	grün
BU	blue	blau
GY	gray	grau
WH	white	weiss
PK	pink	rosa

