

Scope

These operating instructions are valid for all SN 12/16 mm. These operating instructions, the document *Safety information* and any available data sheet form the complete user information for your device.

Important!

Make sure to use the operating instructions valid for your product version. The version numbers can be found on the type label of your product. Please contact the EUCHNER service team if you have any questions.

Safety switch type label

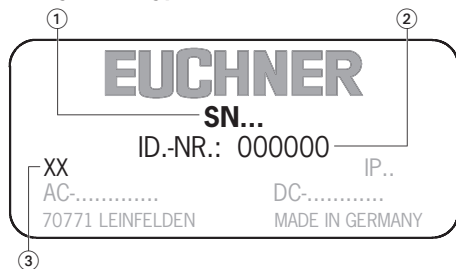

- ① Item designation
- ② Item number
- ③ Production code

Supplementary documents

The overall documentation for this device consists of the following documents:

Document title (document number)	Contents	
Safety information (2525460)	Basic safety information	
Operating instructions (2032308)	(this document)	
Declaration of conformity	Declaration of conformity	
Any additions to the operating instructions	Take any associated additions to the operating instructions or data sheets into account.	

Important!

Always read all documents to gain a complete overview of safe installation, setup and use of the device. The documents can be downloaded from www.euchner.com. For this purpose, enter the doc. no. or the order number for the device in the search box.

Correct use

Precision multiple limit switches series SN are interlocking devices without guard locking (type 1).

The actuator is uncoded (e.g. dogs). In combination with a movable guard and the machine control, this safety component prevents dangerous machine functions from occurring while the guard is open. A stop command is activated if the guard is opened during the dangerous machine function.

For general applications, snap-action switching elements ES502E are used. For use as safety switches, only the switching elements ES508E and ES514 with positively driven contacts are allowed.

This means:

- ▶ Starting commands that cause a dangerous machine function must become active only when the guard is closed.
- ▶ Opening the guard triggers a stop command.
- ▶ Closing a guard must not cause automatic starting of a dangerous machine function. A separate start command must be issued. For exceptions, refer to EN ISO 12100 or relevant C-standards.

Devices from this series can be used as safe position encoders.

Before the device is used, a risk assessment must be performed on the machine, e.g. in accordance with the following standards:

- ▶ EN ISO 13849-1
- ▶ EN ISO 12100
- ▶ EN IEC 62061

Correct use includes observing the relevant requirements for installation and operation, particularly based on the following standards:

- ▶ EN ISO 13849-1
- ▶ EN ISO 14119
- ▶ EN IEC 60204-1

Important!

- ▶ The user is responsible for the proper integration of the device into a safe overall system. For this purpose, the overall system must be validated, e.g. in accordance with EN ISO 13849-1.
- ▶ If the simplified method according to section 6.2.3 of EN ISO 13849-1:2023 is used for determining the Performance Level (PL), the PL might be reduced if several devices are connected in series.
- ▶ The logical series connection of safe contacts may limit the achievable Performance Level (PL) in certain circumstances. More information about this is available in EN ISO 14119:2025, section 9.4.
- ▶ If a data sheet is included with the product, the information on the data sheet applies in case of discrepancies with the operating instructions.

Safety precautions

⚠ WARNING

Danger to life due to improper installation or due to bypassing (tampering). Safety components fulfill a personnel protection function.

- ▶ Safety components must not be bypassed, turned away, removed or otherwise rendered ineffective. On this topic pay attention in particular to the measures for reducing the possibility of bypassing according to EN ISO 14119:2025, section 8.
- ▶ Mounting, electrical connection and setup only by authorized personnel possessing special knowledge about handling safety components.

Function

Precision multiple limit switches are used for positioning and control applications in mechanical and systems engineering.

The switching elements are actuated by means of plungers. Different plungers and trip dogs are used depending on the application (operating point accuracy and approach speed) (see Fig. 4).

In general applications, the plungers are actuated by trip dogs according to DIN 69639 that are mounted with an interference fit in trip rails according to DIN 69638.

The switching contacts are actuated when the actuating element is moved from the free position to the end position. The safety contacts \ominus are positively opened in this process (see Fig. 1).

Switching states

The detailed switching states for your switch can be found in Fig. 1. All available switching elements are described there.

Actuating element in free position

The safety contacts \ominus are closed.

Actuating element in end position

The safety contacts \ominus are open.

Mounting

NOTICE

Device damage due to improper mounting and unsuitable ambient conditions.

- ▶ Safety switches and actuators must not be used as an end stop.
- ▶ Observe EN ISO 14119:2025, sections 6.2 and 6.3, for information about mounting the safety switch and the actuator.
- ▶ Observe EN ISO 14119:2025, section 8, for information about reducing the possibilities for bypassing an interlocking device.
- ▶ For the safety circuits, observe the actuating travel with the tolerances on the dimension drawing.
- ▶ Protect the switch against damage.
- ▶ The specified IP degree of protection is applicable only if the housing screws, cable entries and plug connectors are properly tightened. Observe the tightening torques.

Protection against environmental effects

Safety venting valves are used to equalize the pressure to protect against the pumping action of the plunger. They must not be sealed with paint.

- ▶ Mask plunger, plunger guide, safety venting valves and type label during painting work!

Electrical connection

⚠ WARNING

Loss of the safety function due to incorrect connection.

- ▶ Use only safe contacts (\ominus) for safety functions.
- ▶ Strip the insulation from the ends of the individual wires over a length of 6^{+1} mm to ensure a safe contact.

When switches with indicators that can be retrofitted are used, the voltage range printed on the indicator housing must be observed (for connection, see Fig. 5).

Use of the safety switch as an interlocking device for personnel protection

At least one contact \ominus must be used. This signals the position of the guard (for terminal assignment, see Fig. 1).

The following information applies to devices with plug connector:

- ▶ Check that the plug connector is sealed.

The following information applies to devices with cable entry:

1. Use a suitable tool to open the desired insertion opening.
2. Mount the cable gland with the appropriate degree of protection.
3. Connect and tighten the terminals (for terminal assignment, see Fig. 1; for tightening torque values, see technical data).
4. Check that the cable entry is sealed.
5. Close the switch cover and screw in place (tightening torque 1.5 Nm).

Function test

⚠ WARNING

- Fatal injury due to faults during the function test.
- ▶ Before carrying out the function test, make sure that there are no persons in the danger area.
 - ▶ Observe the valid accident prevention regulations.

Check the device for correct function after installation and after every fault.

Proceed as follows:

Mechanical function test

The actuating element must move easily. Close the guard several times to check the function.

Electrical function test

1. Switch on operating voltage.
2. Close all guards.
 - ➔ The machine must not start automatically.
3. Start the machine function.
4. Open the guard.
 - ➔ The machine must switch off and it must not be possible to start it as long as the guard is open.

Repeat steps 2 - 4 for each guard.

Inspection and service

⚠ WARNING

Danger of severe injuries due to the loss of the safety function.

- ▶ In safety circuits, the entire switch must be replaced in case of damage or wear. Replacement of individual parts or assemblies is not permitted.
- ▶ Check the device for proper function at regular intervals and after every fault. For information about possible time intervals, refer to EN ISO 14119:2025, section 9.2.1.

Inspection of the following is necessary to ensure trouble-free long-term operation:

- ▶ Correct switching function
- ▶ Secure mounting of all components
- ▶ Precise adjustment of trip dogs in relation to multiple limit switch
- ▶ Damage, heavy contamination, dirt and wear
- ▶ Sealing of cable entry
- ▶ Loose cable connections or plug connectors.

Exclusion of liability and warranty

In case of failure to comply with the conditions for correct use stated above, or if the safety regulations are not followed, or if any servicing is not performed as required, liability will be excluded and the warranty void.

Notes about UL requirements

The following information applies to devices with plug connector:

This device is intended to be used with a Class 2 power source in accordance with UL1310. Connecting cables for safety switches installed at the place of use must be separated from all moving and permanently installed cables and un-insulated active elements of other parts of the system that operate at a voltage of over 150 V. A constant clearance of 50.8 mm must be maintained. This does not apply if the moving cables are equipped with suitable insulation materials that possess an identical or higher dielectric strength compared to the other relevant parts of the system.

Declaration of conformity

The product complies with the requirements according to

- ▶ Machinery Directive 2006/42/EC (until January 19, 2027)
- ▶ Machinery Regulation (EU) 2023/1230 (from January 20, 2027)

The EU declaration of conformity can be found at www.euchner.com. Enter the order number of your device in the search box. The document is available under *Downloads*.

Service

If servicing is required, please contact:

EUCHNER GmbH + Co. KG
Kohlhammerstraße 16
70771 Leinfelden-Echterdingen

Service telephone:
+49 711 7597-500

E-mail:
support@euchner.de

Internet:
www.euchner.com

Technical data

Parameter	Value	
Housing material	Die-cast aluminum, anodized	
Plunger material	Stainless steel	
Degree of protection	IP67	
Mech. operating cycles	ES502E / ES508E	30x10 ⁶
	ES514	1x10 ⁶
Electrical life at DC13 24 V/100 mA	ES502E	30 x 10 ⁶
Switching frequency	ES502E	300 min ⁻¹
	ES508E / ES514	50 min ⁻¹
Ambient temperature	-5 ... +80 °C	
Installation position	any	
Approach speed, max.		
Plunger	Chisel D	40 m/min
	Roller R (slide bearing)	80 m/min
	Roller B (ball bearing)	120 m/min
	Dome W/ball K	10 m/min
Approach speed, min.	0.01 m/min	
Actuating force with switching element	ES502E	≥ 20 N
	ES508E	≥ 15 N
	ES514	≥ 30 N
Switching element		
ES502E	1 NO + 1 NC contacts	
ES508E	1 pos. driven contact	
ES514	1 NO + 1 pos. driven contact	
Switching principle		
ES502E/ES514	Snap-action switching contact	
ES508E	Slow-action switching contact	
Hysteresis	ES502E	0.8 mm
	ES514	0.6 mm
Contact material		
ES502E/ES508E/ES514	Silver alloy, gold flashed	
Connection	Screw terminals	
Screw terminal tightening torque (cross-head screw)		
ES502E/ES508E	0.6 Nm	
ES514	0.9 Nm	
Conductor cross-section (rigid/flexible)	0.34 ... 1.5 mm ²	
Rated insulation voltage	U _i = 250 V	
Rated impulse withstand voltage		
ES508E/ES514	U _{imp} = 4 kV	
ES502E	U _{imp} = 2.5 kV	
Utilization category of switching element		
ES502E	AC-12	250 V 8 A
ES502E/ES508E	AC-15	230 V 6 A
	DC-13	24 V 6 A
ES514	AC-15	230 V 2.5 A
	DC-13	24 V 6 A
Switching current, min.		
at DC 24 V	ES514	5 mA
	ES508E	10 mA
at DC 12 V	ES502E	10 mA

Parameter	Value	
Convent. thermal current I _{th}		
ES502E	8 A	
ES508E/ES514	10 A	
Short circuit protection (control circuit fuse)		
ES502E	8 A gG	
ES508E	10 A gG	
ES514	6 A gG	
Conditional short-circuit current	100 A	
Indicator LED	LE060	AC/DC 12 - 60 V
(only with ES502E / ES508E)	LE110	AC 110 V ± 15%
	LE220	AC 220 V ± 15%
For design SN in LED version with switching element ES514 and plunger spacing 12 mm		
	LE024GE	DC 24 V ± 10%
Characteristics acc. to EN ISO 13849-1 for switching elements		
	ES508E	ES514
Safe position sensing		
B _{10D} at DC-13 100 mA/24 V	2 x 10 ⁷	2 x 10 ⁶

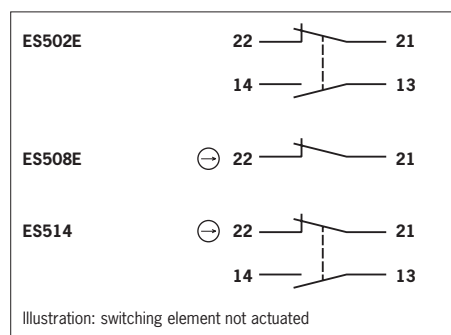

Fig. 1: Switching elements and terminal assignment

Subject to technical modifications; no responsibility is accepted for the accuracy of this information. © EUCHNER GmbH + Co. KG 2032308-11-02/26 (translation of the original operating instructions)

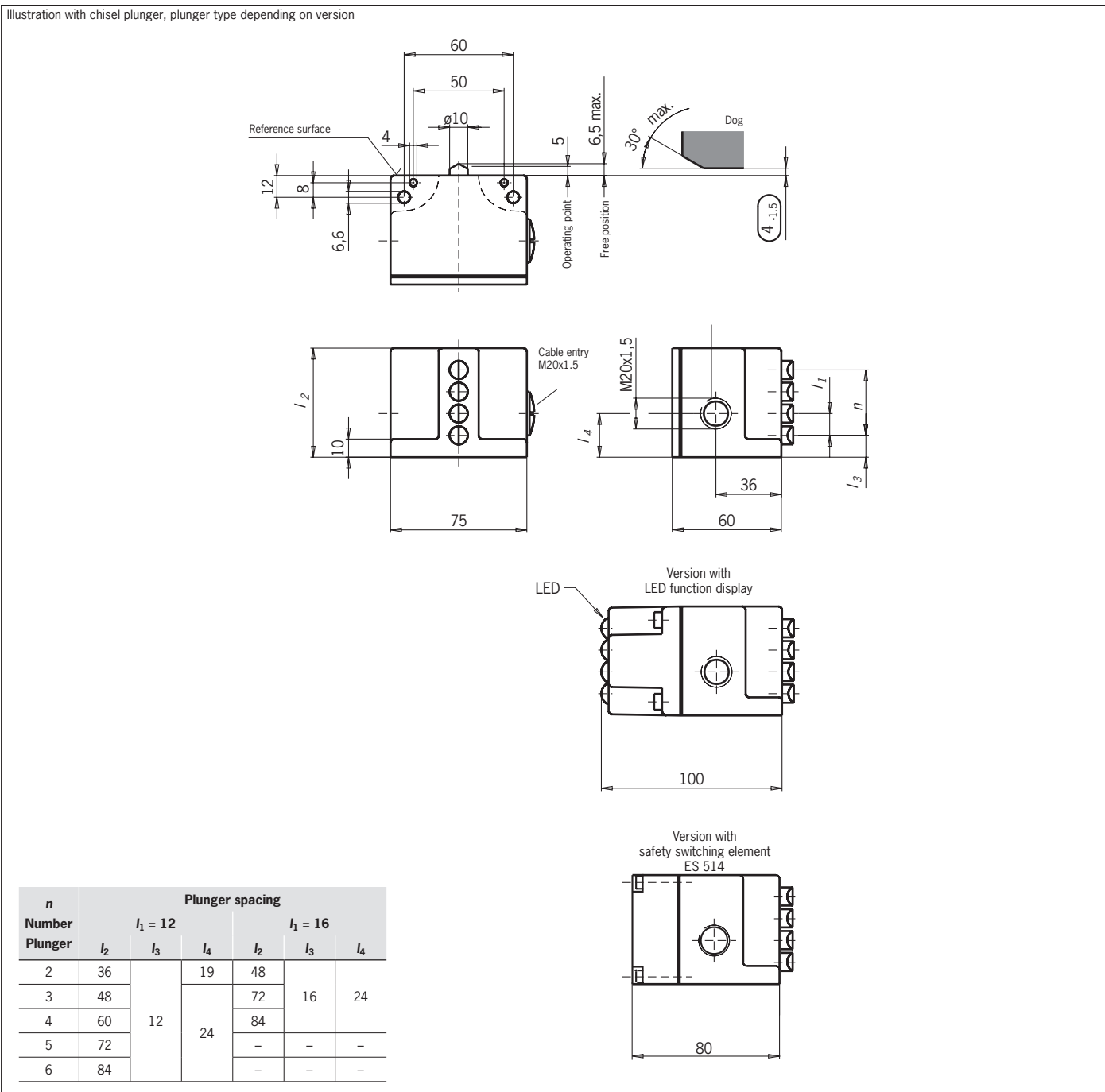

Fig. 2: Dimension drawing for SN...

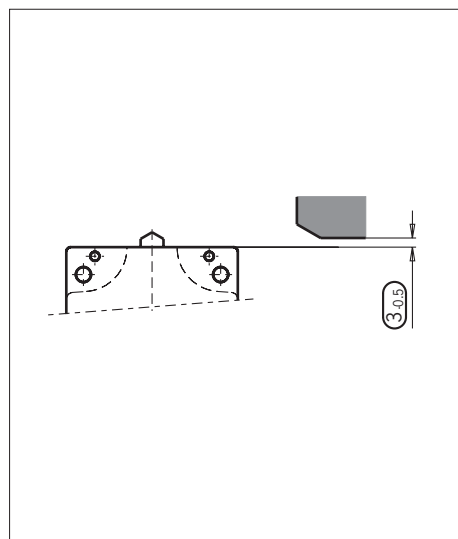

Fig. 3: Mounting SN...-508 and SN...-514 for safety circuits

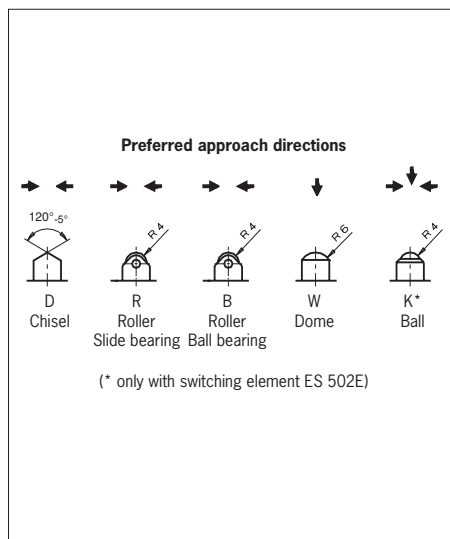

Fig. 4: Plungers and approach directions

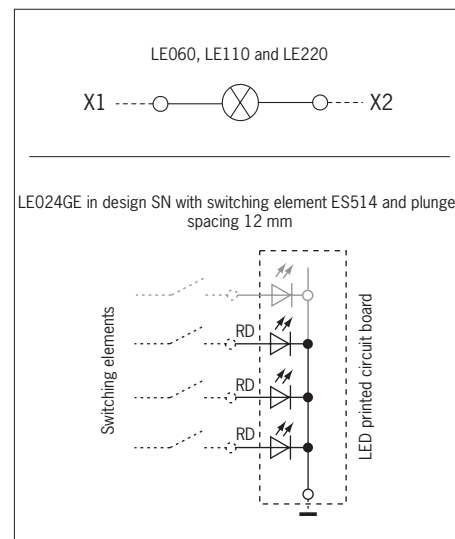

Fig. 5: Connection of LED indicators