

EUCHNER

Operating Instructions

Contents

1.	About this document	4
1.1.	Scope.....	4
1.2.	Target group	4
1.3.	Key to symbols.....	4
1.4.	Supplementary documents	4
2.	Correct use	5
3.	Description of the safety function	6
4.	Exclusion of liability and warranty	7
5.	General safety precautions	7
6.	Function	8
6.1.	Door position monitoring output (OD).....	8
6.2.	Diagnostic monitoring output (OI)	8
6.3.	Version MGBS Extended.....	8
6.4.	Switching states	8
7.	System overview	9
7.1.	Interlocking module MGBS-P-I-... ..	9
7.2.	Handle module MGBS-H-... ..	9
7.3.	Inner door handle MGB-E-... (optional).....	9
7.4.	Dimension drawing (example illustration).....	10
7.5.	Drilling pattern (example illustration)	11
8.	Manual release	12
8.1.	Escape release MGB-E-... (optional).....	12
8.1.1.	Preparing escape release	12
8.2.	Lockout mechanism.....	13
9.	Changing actuating direction of the interlocking module	14
10.	Mounting	15
10.1.	Mounting examples	15
10.2.	Mounting lens	16

11.	Electrical connection	17
11.1.	Notes about UL	17
11.2.	Safety in case of faults.....	18
11.3.	Fuse protection for power supply	18
11.4.	Requirements for connecting cables.....	18
11.5.	Connector assignment of interlocking modules MGBS-...-AP-...-SA-... with plug connector M12, 8-pin .	19
11.6.	Connection of MGBS-I-AP	20
11.7.	Notes on operation with safe control systems.....	21
12.	Setup	22
12.1.	LED displays	22
12.2.	Teach-in function for handle module (only for unicode evaluation)	22
12.2.1.	Teaching-in handle module	23
12.3.	Functional check.....	23
12.3.1.	Mechanical function test.....	23
12.3.2.	Electrical function test.....	23
13.	System status table	24
14.	Technical data	25
14.1.	Technical data for interlocking module MGBS-P-I-AP	25
14.1.1.	Typical system times.....	26
14.2.	Operating distances.....	26
14.3.	Radio frequency approvals.....	27
14.4.	Dimension drawings for variants	28
15.	Ordering information and accessories	29
16.	Inspection and service	29
17.	Service	29
18.	Declaration of conformity	29

1. About this document

1.1. Scope





These operating instructions are valid for all MGBS-P-I-AP... of version V1.1.X. These operating instructions, the document *Safety information* and any available data sheet form the complete user information for your device.

	<p>Important!</p> <p>Make sure to use the operating instructions valid for your product version. Please contact the EUCHNER service team if you have any questions.</p>
---	--

1.2. Target group





Design engineers and installation planners for safety systems on machines, as well as setup and servicing staff possessing special expertise in handling safety components.

1.3. Key to symbols

Symbol/depiction	Meaning
	Printed document
	Document is available for download at www.euchner.com
	This section is applicable only if the memory card is used
 DANGER WARNING CAUTION	<p>Safety precautions</p> <p>Danger of death or severe injuries</p> <p>Warning about possible injuries</p> <p>Caution slight injuries possible</p>
 NOTICE Important!	<p>Notice about possible device damage</p> <p>Important information</p>
Tip	Useful information

1.4. Supplementary documents

The overall documentation for this device consists of the following documents:

Document title (document number)	Contents	
Safety information (2525460)	Basic safety information	
Operating instructions (2527247)	(this document)	
Declaration of conformity	Declaration of conformity	
Possibly available data sheet	Item-specific information about deviations or additions	 

	<p>Important!</p> <p>Always read all documents to gain a complete overview of safe installation, setup and use of the device. The documents can be downloaded from www.euchner.com. For this purpose enter the doc. no. in the search box.</p>
---	--

2. Correct use

The safety system MGBS consists at minimum of one interlocking module MGBS-P-I-... and one handle module MGBS-H... and is an interlocking device without guard locking (type 4). Devices with unicode evaluation possess a high coding level, devices with multicode evaluation possess a low coding level.

In combination with a movable guard and the machine control, this safety component prevents dangerous machine functions from occurring while the guard is open. A stop command is activated if the guard is opened during the dangerous machine function.

This means:

- › Starting commands that cause a dangerous machine function must become active only when the guard is closed.
- › Opening the guard triggers a stop command.
- › Closing a guard must not cause automatic starting of a dangerous machine function. A separate start command must be issued. For exceptions, refer to EN ISO 12100 or relevant C-standards.

Before the device is used, a risk assessment must be performed on the machine, e.g. in accordance with the following standards:

- › EN ISO 13849-1
- › EN ISO 12100
- › EN IEC 62061

Correct use includes observing the relevant requirements for installation and operation, particularly based on the following standards:

- › EN ISO 13849-1
- › EN ISO 14119
- › EN IEC 60204-1

The interlocking module is allowed to be operated only in conjunction with the intended EUCHNER handle module and the related connection components from EUCHNER. On the use of other handle modules or other connection components, EUCHNER provides no warranty for safe function.



Important!

- › The user is responsible for the proper integration of the device into a safe overall system. For this purpose, the overall system must be validated, e.g. in accordance with EN ISO 13849-1.
- › Correct use requires observing the permissible operating parameters (see chapter 14. *Technical data on page 25*).
- › If a data sheet is included with the product, the information on the data sheet applies.
- › It is only allowed to use components that are permissible in accordance with the table below.

Table 1: Possible combinations for MGBS components

Interlocking module		Handle module
		MGBS-H...
MGBS...	●	
Key to symbols	●	Combination possible

3. Description of the safety function

Devices from this series feature the following safety functions:

Monitoring of the guard position (interlocking device according to EN ISO 14119)

- › Safety function (see chapter 6.4. *Switching states on page 8*):
 - The safety outputs are switched off when the guard is open (monitoring of the door position).
- › Safety characteristics: category, Performance Level, PFH (see chapter 14. *Technical data on page 25*).

The following applies to devices with emergency stop:

Emergency stop (emergency stop device according to EN ISO 13850)

- › Safety function: emergency stop function
- › Safety characteristics: B10D value (see associated data sheet)

4. Exclusion of liability and warranty

In case of failure to comply with the conditions for correct use stated above, or if the safety regulations are not followed, or if any servicing is not performed as required, liability will be excluded and the warranty void.

5. General safety precautions

Interlocking modules fulfill personnel protection functions. Incorrect installation or tampering can lead to fatal injuries to personnel.

Check the safe function of the guard particularly

- › after any setup work
- › after the replacement of a system component
- › after an extended period without use
- › after every fault.

Independent of these checks, the safe function of the guard should be checked at suitable intervals as part of the maintenance schedule.



WARNING

Danger to life due to improper installation or due to bypassing (tampering). Safety components perform a personnel protection function.

- › Safety components must not be bypassed, turned away, removed or otherwise rendered ineffective. On this topic pay attention in particular to the measures for reducing the possibility of bypassing according to EN ISO 14119:2025, section 7.
- › The switching operation may be triggered only by handle modules designated for this purpose.
- › Prevent bypassing by means of replacement handle modules (only for multicode evaluation). For this purpose, restrict access to handle modules and to keys for releases, for example.
- › Mounting, electrical connection and setup only by authorized personnel possessing the following knowledge:
 - specialist knowledge in handling safety components
 - knowledge about the applicable EMC regulations
 - knowledge about the applicable regulations on operational safety and accident prevention.



Important!

Prior to use, read the operating instructions and keep these in a safe place. Ensure the operating instructions are always available during mounting, setup and servicing. EUCHNER cannot provide any warranty in relation to the readability of the CD for the storage period required. For this reason you should archive a printed copy of the operating instructions. You can download the operating instructions from www.euchner.com.

6. Function

The device monitors the position of movable guards.

The system consists of the following components: coded handle module (transponder) and interlocking module.

Whether the device learns the complete transponder code (unicode) or not (multicode) depends on the respective version.

- **Devices with unicode evaluation:** The handle module must be assigned to the interlocking module by a teach-in operation so that it is detected by the system. This unambiguous assignment ensures a particularly high level of protection against tampering. The system thus possesses a high coding level.
- **Devices with multicode evaluation:** Unlike systems with unicode evaluation, on multicode devices a specific code is not requested but instead it is only checked whether the handle module is of a type that can be detected by the system (multicode evaluation). There is no exact comparison of the transponder code with the taught-in code in the interlocking module (unicode evaluation). The system possesses a low coding level.

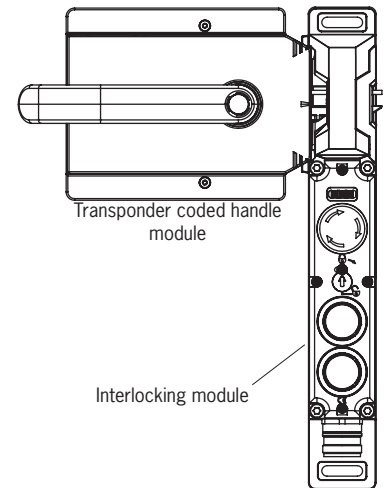

The bolt tongue on the handle module is inserted into the interlocking module when the guard is closed. When the operating distance is reached, power is supplied to the transponder in the handle module by the interlocking module and data are transferred.

If a permissible code is detected, the safety outputs are switched on.

The safety outputs are switched off when the guard is opened.

In the event of a fault in the interlocking module, the safety outputs are switched off and the DIA LED illuminates red. The occurrence of faults is detected at the latest on the next demand to close the safety outputs (e.g. on starting).

6.1. Door position monitoring output (OD)

The door position monitoring output is switched on as soon as the bolt tongue of the handle module is inserted into the interlocking module (state: guard closed).

6.2. Diagnostic monitoring output (OI)

The diagnostic monitoring output is switched on in the event of a fault (switch-on condition as for DIA LED).

6.3. Version MGBS Extended

Some versions contain additional controls/indicators in the housing cover. Please refer to the corresponding data sheet for further information.

6.4. Switching states

The detailed switching states for your interlocking module can be found in the system status table. All safety outputs, monitoring outputs and display LEDs are described there.

	Guard closed (bolt tongue fully inserted into interlocking module)	Guard open
Safety outputs FO1A and FO1B	on	off
Door position monitoring output OD	on	off

7. System overview

7.1. Interlocking module MGBS-P-I-...

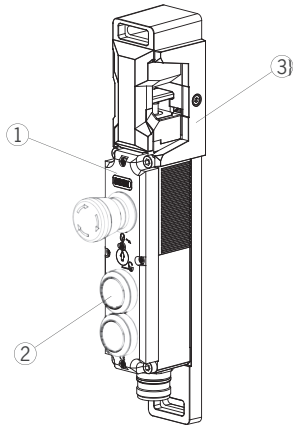

Key:

- ① Interlocking module
- ② Optionally with Extended version
- ③ Stop plate



NOTICE

- Depending on the version, additional controls and indicators may be integrated.
- Depending on the version, a mounting plate can be included. See associated data sheet.

7.2. Handle module MGBS-H-...

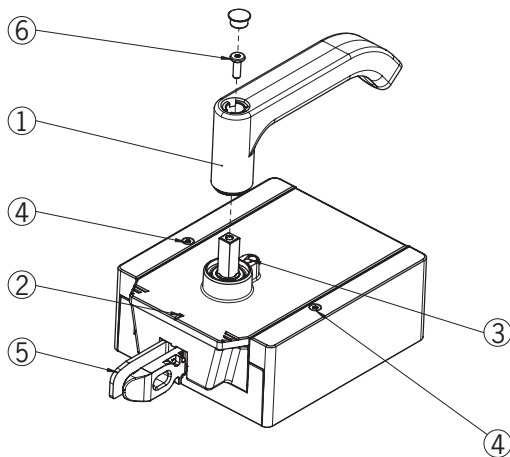

Key:

- ① Door handle
- ② Marking for adjustment
- ③ Locking pin for changing the rotating direction of the door handle
- ④ Locking screws T10 for housing cover
- ⑤ Bolt tongue
- ⑥ Fixing screw



NOTICE

- Depending on the version, a mounting plate can be included. See associated data sheet.

7.3. Inner door handle MGB-E-... (optional)

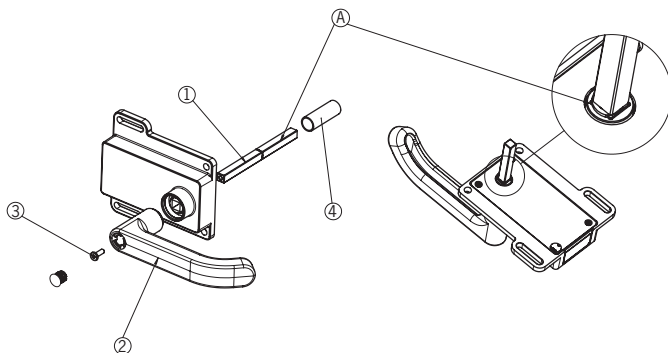

Key:

- A Snap ring
- ① Actuation axis
- ② Door handle
- ③ Fixing screw
- ④ Protective sleeve



NOTICE

- Depending on the version, a mounting plate can be included. See associated data sheet.

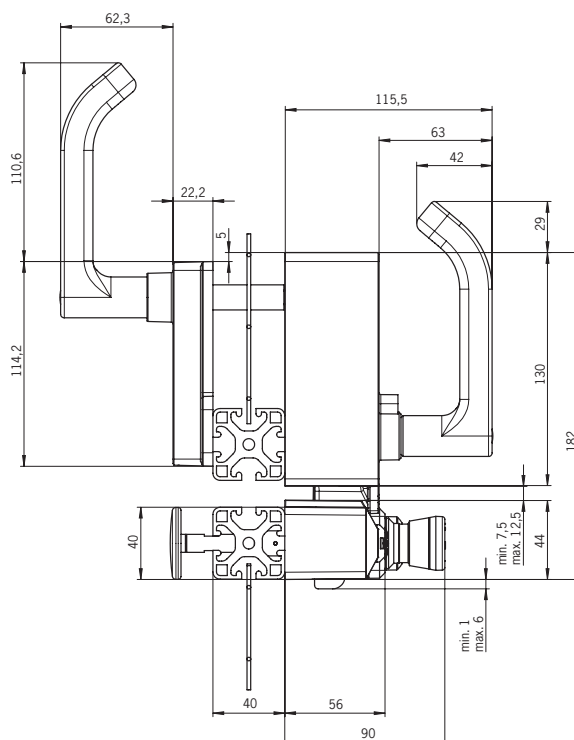
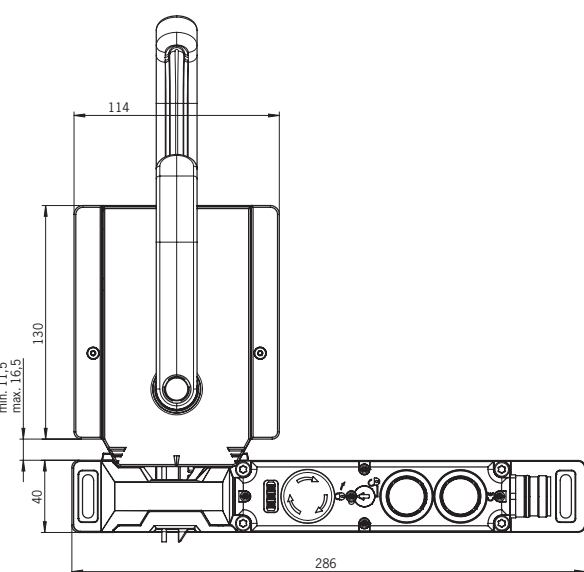
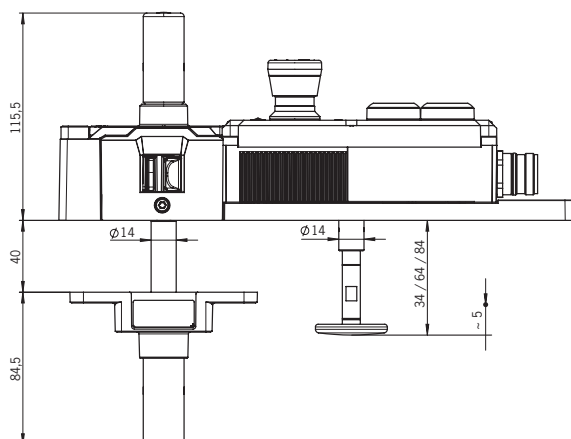
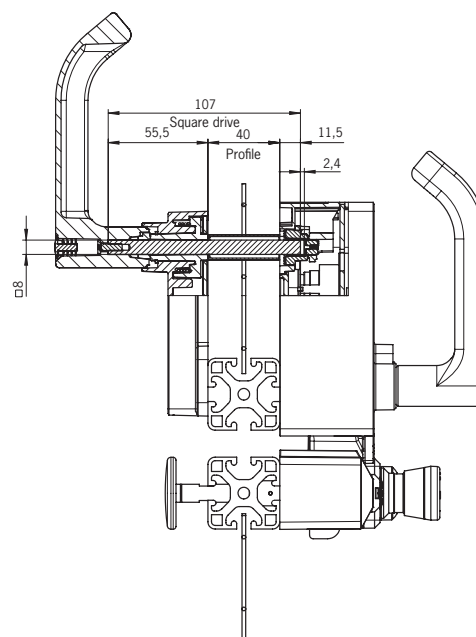
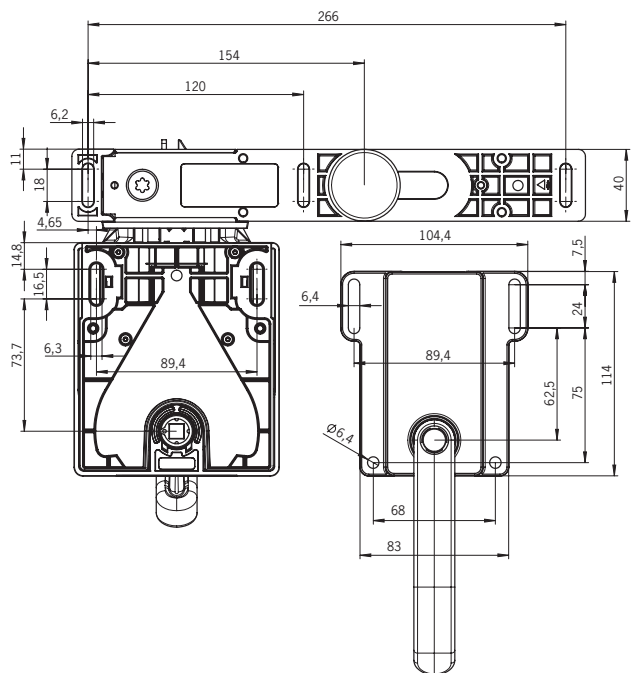

7.4. Dimension drawing (example illustration)

7.5. Drilling pattern (example illustration)

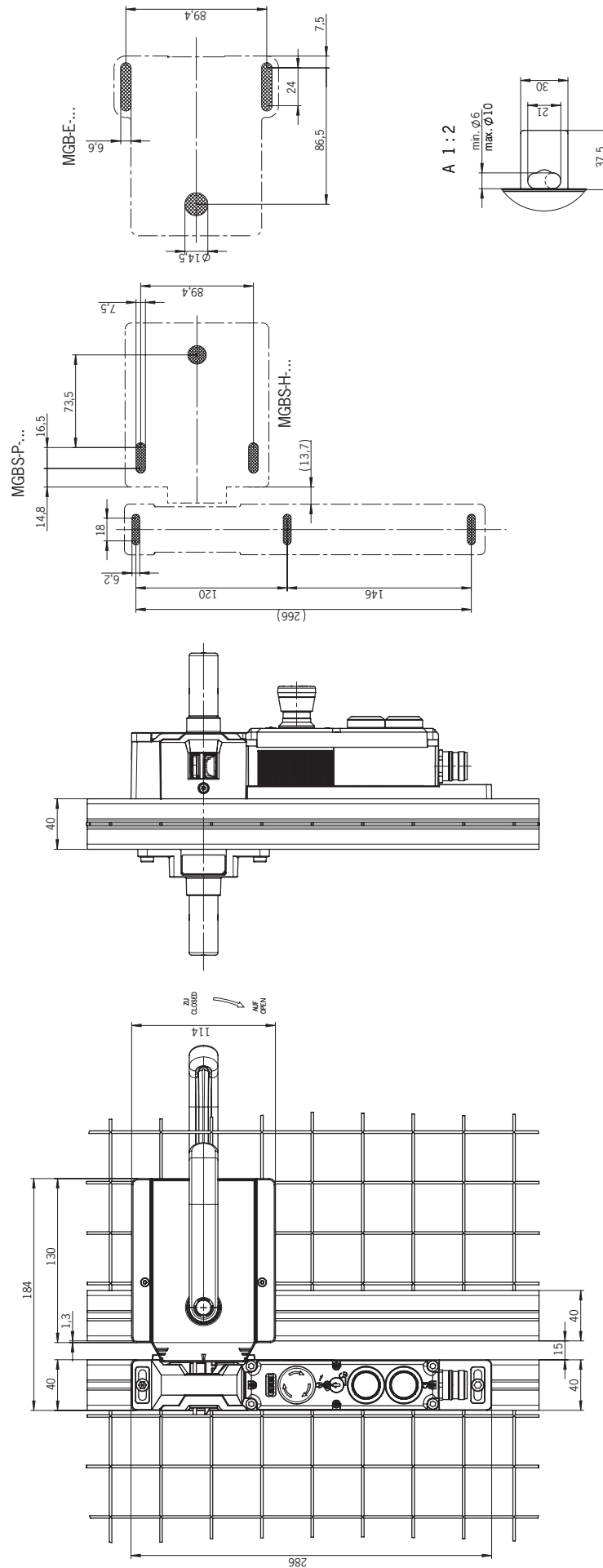

8. Manual release

8.1. Escape release MGB-E-... (optional)

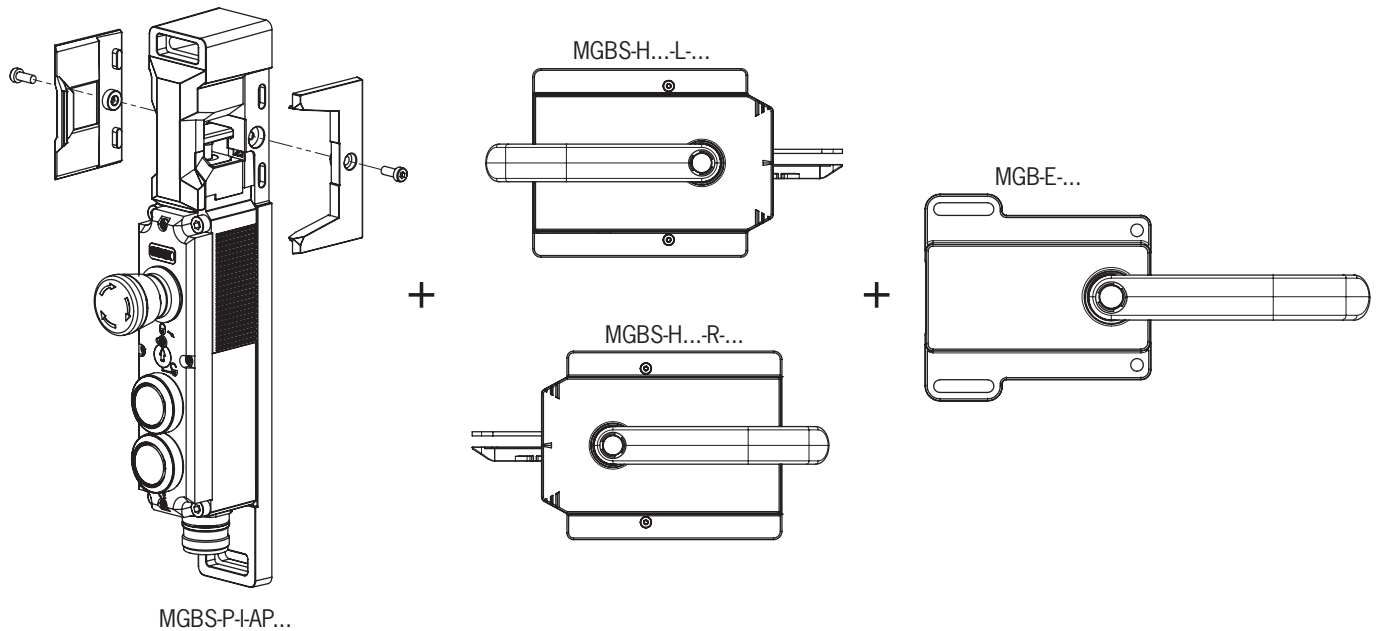

8.1.1. Preparing escape release



NOTICE

Various inner door handles with different axis lengths are available, as well as mounting plates and door handles/door knobs. You will find further information at www.euchner.com.

Profile width	Required length Actuation axis		Which EUCHNER parts are required?	Necessary work steps
	Without mounting plates	With mounting plates (4 mm each)		
D	D+9	D+17		
30 mm	39 mm	47 mm	Standard escape release with 107 mm axis (order no. 100465)	Shorten to required length
40 mm	49 mm	57 mm	Standard escape release with 107 mm axis (order no. 100465) If necessary, extended actuation axis (order no. 106761)	<i>Without mounting plates:</i> None <i>With mounting plates:</i> Use extended actuation axis and protective sleeve and shorten to required length
45 mm	54 mm	62 mm	Standard escape release with 107 mm axis (order no. 100465) and extended actuation axis (order no. 106761)	Use extended actuation axis and protective sleeve and shorten to required length
50 mm	59 mm	67 mm	Standard escape release with 107 mm axis (order no. 100465) and extended actuation axis (order no. 106761)	Use extended actuation axis and protective sleeve and shorten to required length

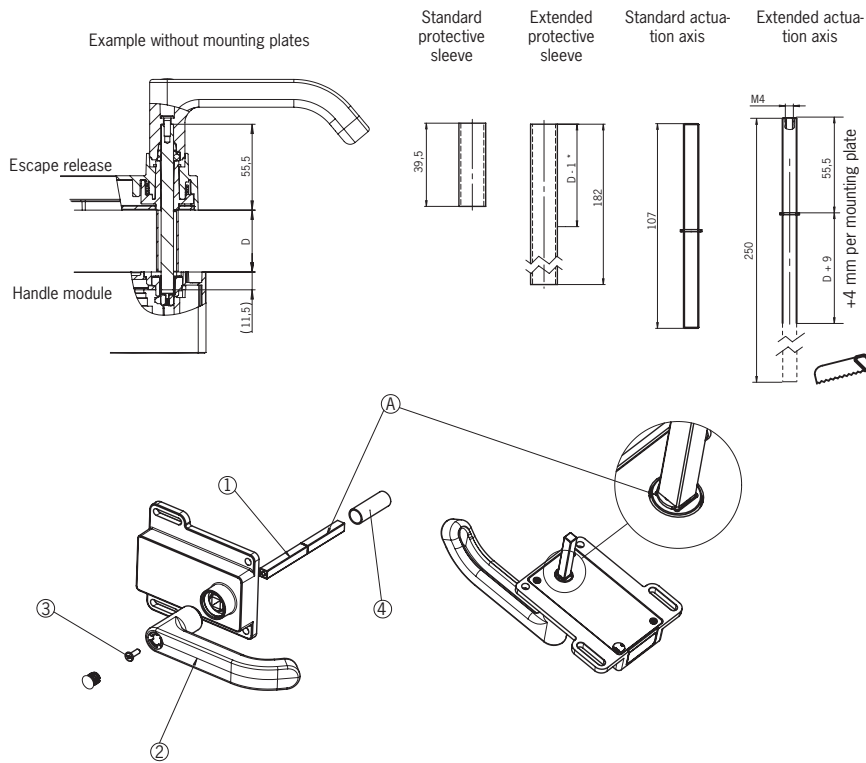

8.2. Lockout mechanism

The lockout mechanism can be secured with padlocks (see Fig. 1). This is intended to prevent people from being locked in unintentionally. The lockout mechanism does not fulfill any safety function.

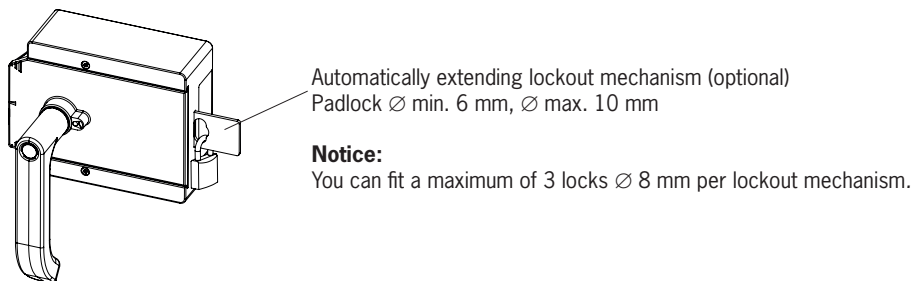

Fig. 1: Lockout mechanism secured with padlock

9. Changing actuating direction of the interlocking module



NOTICE

- › When using sliding doors, you are recommended to use the door knob AY-DKB...
- › When changing the actuating direction, please use a screwdriver (TX20).
- › The actuating direction of handle module MGBS-H... cannot be changed.

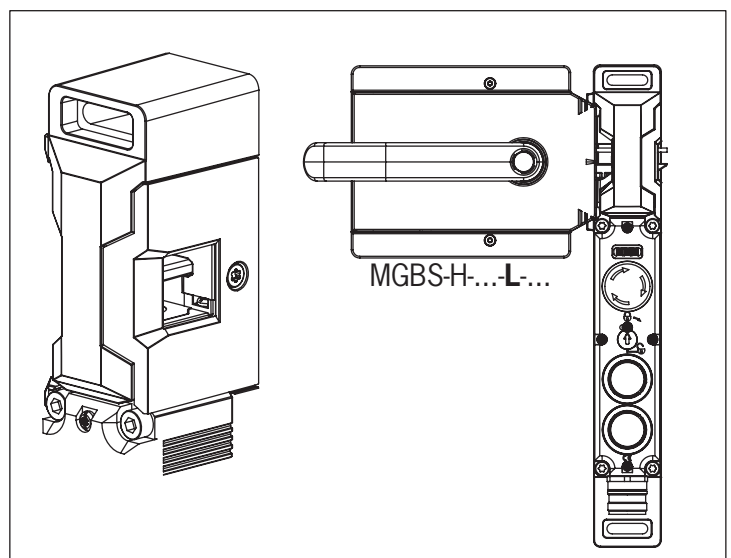
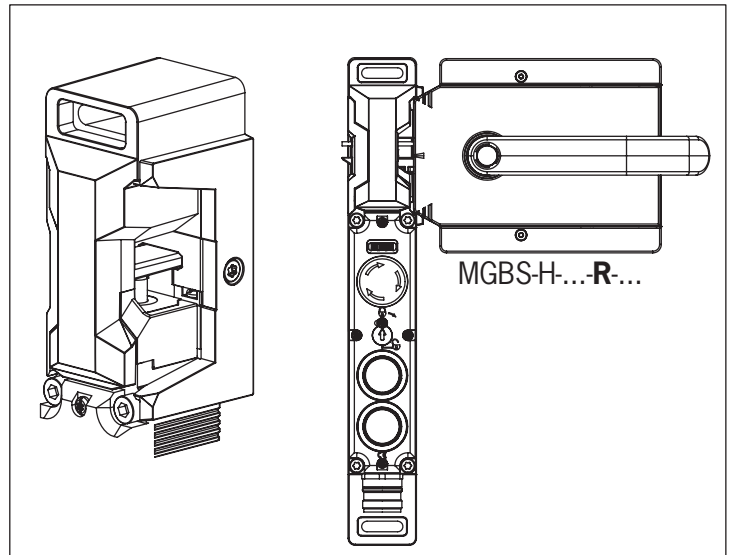
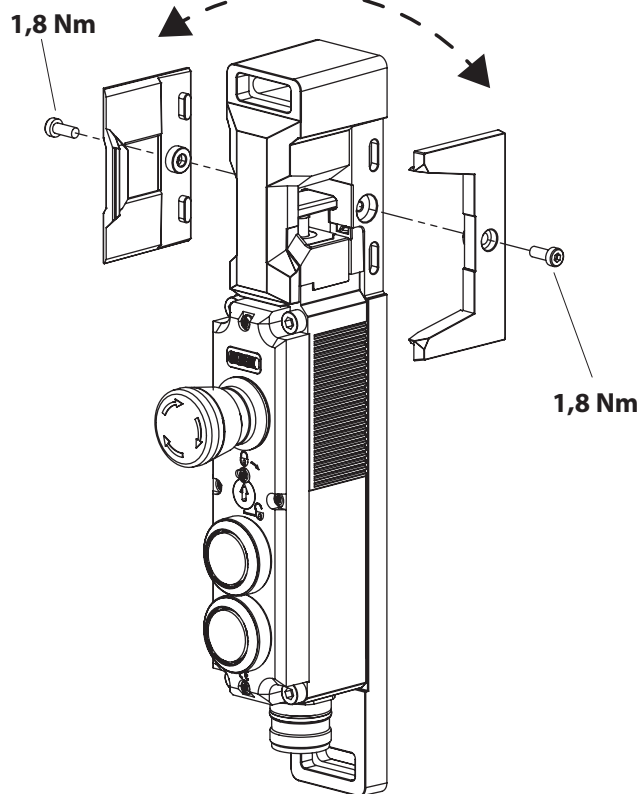

10. Mounting



CAUTION

Interlocking modules must not be bypassed (bridging of contacts), turned away, removed or otherwise rendered ineffective.

- › Observe EN ISO 14119:2025, section 8, for information about reducing the possibilities for bypassing an interlocking device.



NOTICE

Risk of damage to equipment and malfunctions as a result of incorrect installation.

- › The bolt tongue must not be used as a door stop.
- › The locking module's stop plate may be used as a stop plate only for hinged doors.
- › A separate, additional door stop must be used on sliding doors.
- › Observe EN ISO 14119:2025, sections 6.2 and 6.3, for information about fastening the interlocking module and the handle module.
- › Protect the device/the system/the interlocking module head against damage, as well as penetrating foreign objects such as swarf, sand and blasting shot, etc.
- › Observe the tightening torque for fastening the interlocking module (max. 1.4 Nm).
- › With two-leaf hinged doors, one of the two door leaves must also be latched mechanically.

10.1. Mounting examples

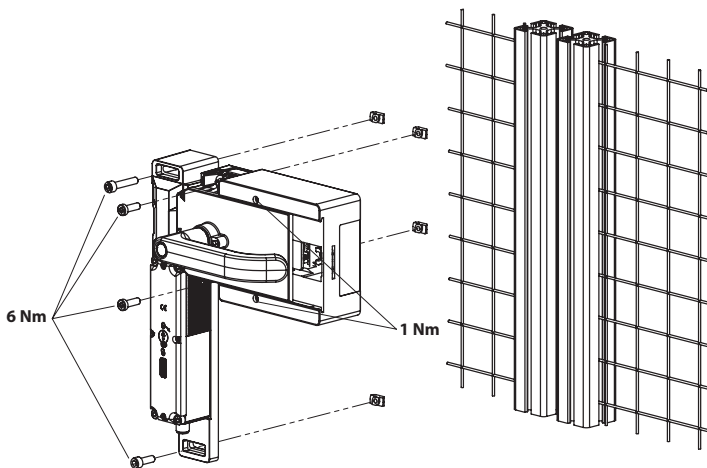

Fig. 2: Mounting situation without escape release

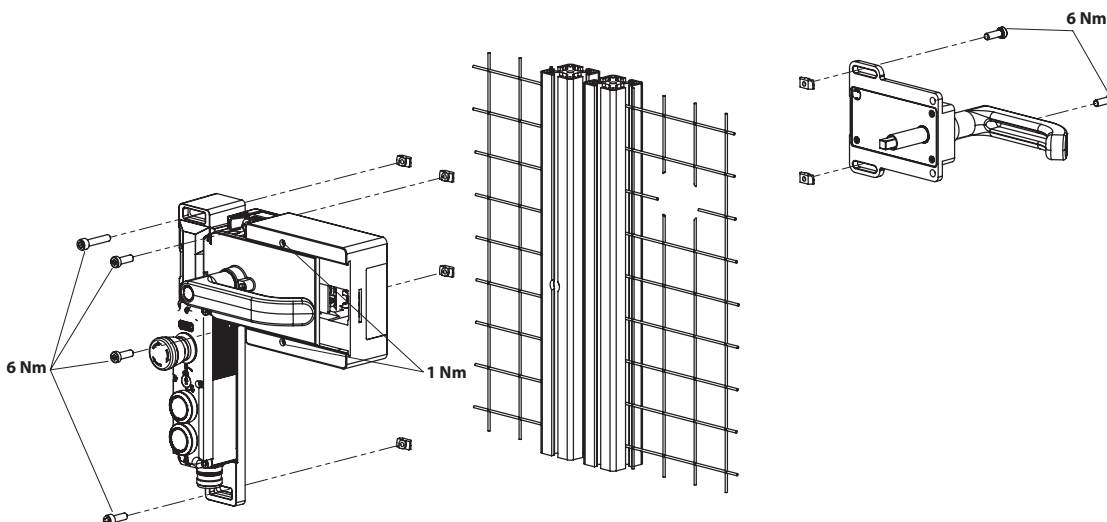
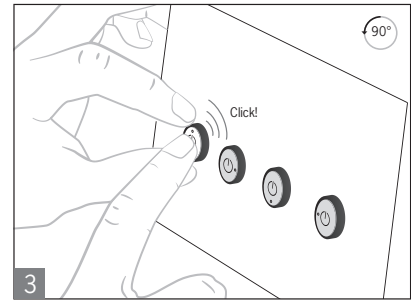
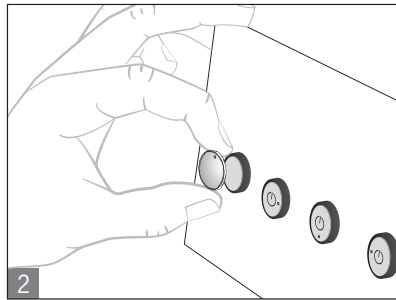
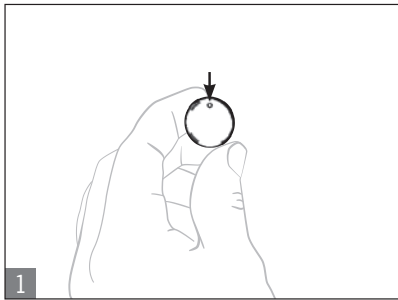

Fig. 3: Mounting situation with escape release

10.2. Mounting lens

Mounting



Removal

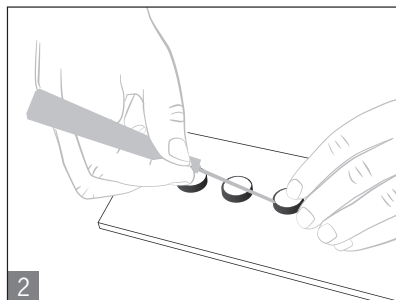
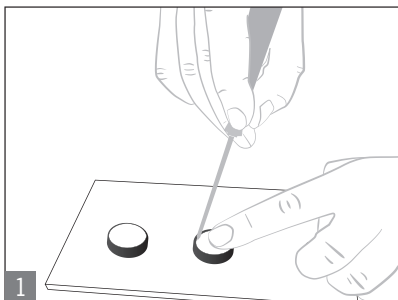

11. Electrical connection

	<p>WARNING</p> <p>In the event of a fault, loss of the safety function due to incorrect connection.</p> <ul style="list-style-type: none"> › To ensure safety, both safety outputs (FO1A and FO1B) must always be evaluated. › Monitoring outputs must not be used as a safety output. › Lay the connecting cables with protection to prevent the risk of short circuits.
	<p>CAUTION</p> <p>Risk of damage to equipment or malfunctions as a result of incorrect connection.</p> <ul style="list-style-type: none"> › The device generates its own test pulses on the output lines FO1A/FO1B. A downstream control system must tolerate these test pulses, which may have a length of up to 0.35 ms. Depending on the inertia of the downstream device (control system, relay, etc.), this can lead to short switching processes. › The inputs on an evaluation unit connected must be positive switching, as the two outputs on the interlocking module deliver a level of +24 V in the switched-on state. › All electrical connections must either be isolated from the mains supply by a safety transformer according to IEC 61558-2-6 with limited output voltage in the event of a fault, or by other equivalent insulation measures (PELV). › All electrical outputs must have an adequate protective circuit for inductive loads. The outputs must be protected with a free-wheeling diode for this purpose. Varistors and RC interference suppression units must not be used. › Power devices which are a powerful source of interference must be installed in a separate location away from the input and output circuits for signal processing. The cable routing for safety circuits should be as far away as possible from the cables of the power circuits. › To avoid EMC interference, the physical environmental and operating conditions at the installation site of the device must comply with the requirements according to the standard EN IEC 60204-1:2006, section 4.4.2 (EMC). › Please pay attention to any interference fields from devices such as frequency converters or induction heating systems. Observe the EMC instructions in the manuals from the respective manufacturer. › In devices with IMP/IMM inputs, the power supply for the evaluation electronics is separate from the power supply for the guard locking solenoid. › If different power supplies are used, they must have the same reference potential.
	<p>Important!</p> <p>If the device does not appear to function when operating voltage is applied (e.g. green STATE LED does not flash), the interlocking module must be returned unopened to the manufacturer.</p>

11.1. Notes about UL

	<p>Important!</p> <ul style="list-style-type: none"> › This device is intended to be used with a Class 2 power source in accordance with UL1310¹⁾. Alternative solutions must comply with the following requirements: This device shall be used with a suitable isolating source in conjunction with a fuse in accordance with UL248. The fuse shall be rated max. 3.3 A and be installed in the max. 30 V DC power supply to the device in order to limit the available current. › For use and application as per the requirements of UL ¹⁾ a connecting cable listed under the UL category code CYJV/7, min. 24 AWG, min. 80 °C, must be used. <p><small>1) Note on the scope of the UL approval: the devices have been tested as per the requirements of UL508 and CSA/ C22.2 no. 14 (protection against electric shock and fire).</small></p>
--	--

11.2. Safety in case of faults

- › The safety outputs FO1A/FO1B are short circuit-proof.
- › A short circuit between FO1A and FO1B is detected by the interlocking module.
- › A short circuit in the cable can be excluded by laying the cable with protection.

11.3. Fuse protection for power supply

The power supply must be provided with fuse protection depending on the number of interlocking modules and the current required for the outputs. The following rules apply:

Max. current consumption of an individual interlocking module I_{max}

$$I_{max} = I_{UB} + I_{FO1A+FO1B} + I_{OD}$$

I_{UB} = Operating current of interlocking module (40 mA)

I_{OD} = Load current of monitoring outputs (max. 50 mA per monitoring output)

$I_{FO1A+FO1B}$ = Load current of safety outputs FO1A + FO1B (2 x max. 150 mA)

11.4. Requirements for connecting cables



CAUTION

Risk of damage to equipment or malfunctions as a result of incorrect connecting cables.

- › Use connection components and connecting cables from EUCHNER.
- › If other connection components are used, the requirements in the following table apply. EUCHNER provides no warranty for safe function in case of failure to comply with these requirements.

Observe the following requirements with respect to the connecting cables:

Interlocking modules MGBS-...-AP-...-SBB-...



Parameter	Value	Unit
Conductor cross-section, min.	0.25	mm ²
R max.	60	Ω/km
C max.	120	nF/km
L max.	0.65	mH/km
Recommended cable type	5 x 0.34 mm ²	

For interlocking modules MGBS-...-AP-...-SA-... with plug connector M12, 8-pin

Parameter	Value	Unit
Conductor cross-section, min.	0.25	mm ²
R max.	60	Ω/km
C max.	120	nF/km
L max.	0.65	mH/km
Recommended cable type	LIYY 8 x 0.25 mm ²	

11.5. Connector assignment of interlocking modules MGBS-...-AP-...-SA-... with plug connector M12, 8-pin

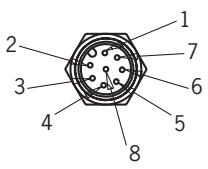
Wiring diagram C

Plug connector (view of connection side)	Pin	Designation	Function	Conductor coloring of connecting cable ¹⁾
<p>1 x M12</p> 	1	n.c.	-	WH
	2	UB	Electronics operating voltage, 24 V DC	BN
	3	F01A	Safety output, channel A 	GN
	4	F01B	Safety output, channel B 	YE
	5	OI	Diagnostic monitoring output	GY
	6	OD	Door position monitoring output	PK
	7	OVUB	Electronics operating voltage, 0 V DC	BU
	8	n.c.	-	RD

1) Only for standard EUCHNER connecting cable

11.6. Connection of MGBS-I-AP

Connect the device as shown in Fig. 4. The monitoring outputs can be routed to a control system.



WARNING

In the event of a fault, loss of the safety function due to incorrect connection.
 › To ensure safety, both safety outputs (FO1A and FO1B) must always be evaluated.



Important!

› The example shows only an excerpt that is relevant for the connection of the MGBS system. The example illustrated here does not show complete system planning. The user is responsible for safe integration into the overall system. Detailed application examples can be found at www.euchner.com. Simply enter the order number of your interlocking module in the search box. You will find all available connection examples for the device in *Downloads*.

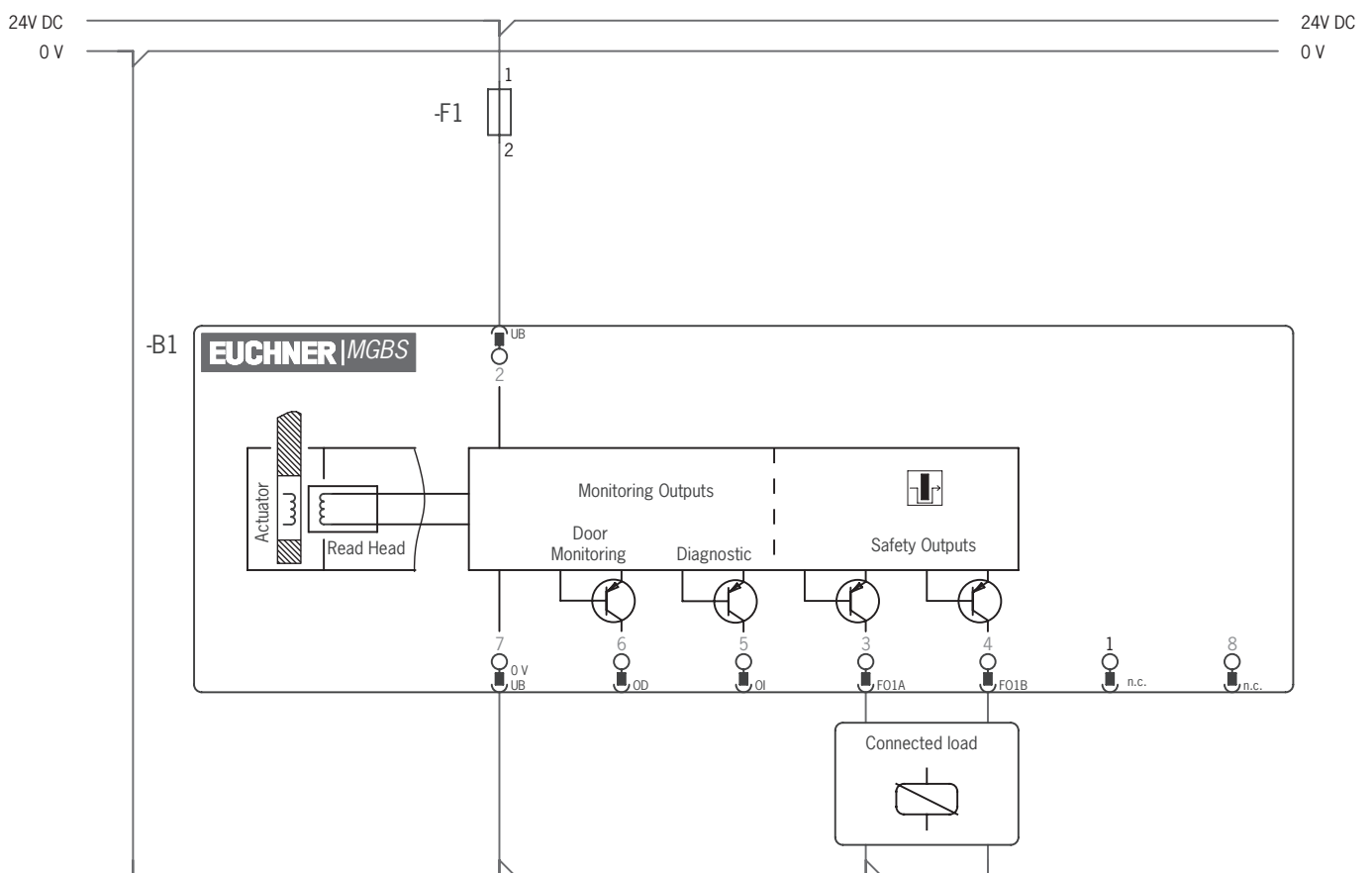

Fig. 4: Connection example, version with plug connector M12

11.7. Notes on operation with safe control systems

Observe the following guidelines for connection to safe control systems:

- ▶ Use a common power supply for the control system and the connected interlocking modules.
- ▶ The device tolerates voltage interruptions on UB of up to 5 ms. Tap the supply voltage directly from the power supply unit. If the power supply is connected to a terminal of a safe control system, this output must provide sufficient electrical current.
- ▶ The safety outputs (FO1A and FO1B) can be connected to the safe inputs of a control system. Prerequisite: the input must be suitable for pulsed safety signals (OSSD signals, e.g. from light grids). The control system must tolerate test pulses on the input signals. This normally can be set up by parameter assignment in the control system. Observe the notes of the control system manufacturer. For the pulse duration of your interlocking module, please refer to chapter 14. *Technical data on page 25.*

A detailed example of connecting and setting the parameters of the control system is available for many devices at www.euchner.com, in the area Download ➔ Applications ➔ MGBS. The features of the respective device are dealt with there in greater detail.

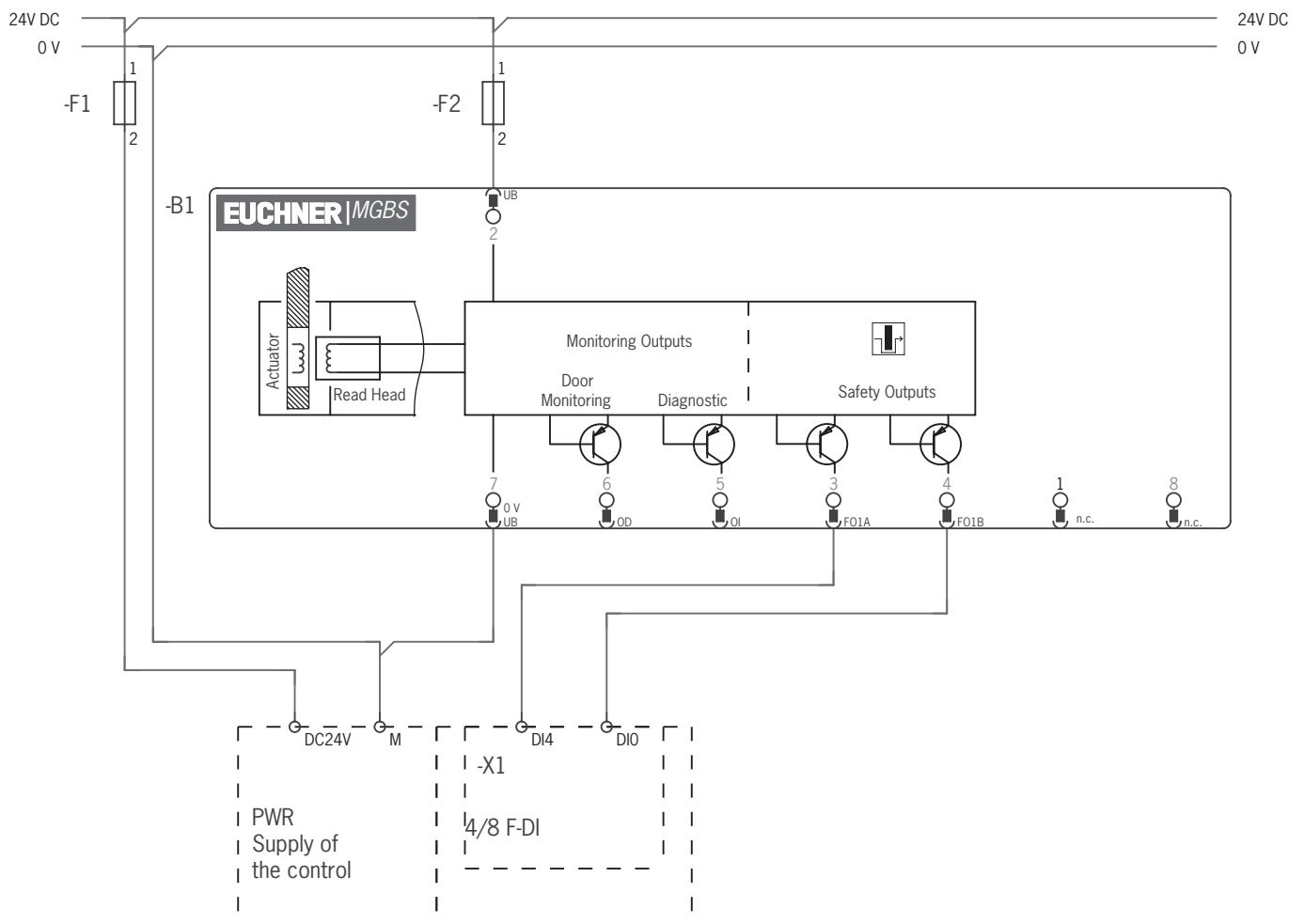

Fig. 5: Connection example for the connection to ET200

12. Setup

12.1. LED displays

You will find a detailed description of the signal functions in chapter 13. *System status table on page 24.*

LED	Color
STATE	green
DIA	red

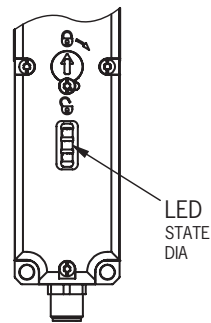

12.2. Teach-in function for handle module (only for unicode evaluation)

The handle module must be assigned to the interlocking module using a teach-in function before the system forms a functional unit.

During a teach-in operation, the safety outputs are switched off, i.e. the system is in the safe state.

The teach-in operation is automatic. The number of possible teach-in operations is unlimited.



Tip!

Prior to switching on, close the guard on which the handle module to be taught-in is installed. The teach-in operation starts immediately after switching on. This feature simplifies above all teach-in with series connections and on large installations.



Important!

- › The teach-in operation can be performed only if the device does not have any internal fault.
- › Devices in the condition as supplied remain in teach-in standby until you have successfully taught-in the first handle module. Once taught-in, interlocking modules remain in teach-in standby for approx. 3 min. after each switch-on.
- › The interlocking module disables the code for the previous handle module if teach-in is carried out for a new handle module. Teach-in is not possible again immediately for this device if a new teach-in operation is carried out. The disabled code is released again in the interlocking module only after a third code has been taught-in.
- › The interlocking module can be operated only with the last handle module taught-in.
- › If, in teach-in standby, the interlocking module detects the handle module last taught-in, teach-in standby is ended immediately and the interlocking module changes to the normal state.
- › The handle module to be taught-in is not activated if it is within the actuating range for less than 30 s.

12.2.1. Teaching-in handle module

1. Establish teach-in standby:
 - Devices in the condition as supplied: unlimited teach-in standby after switching on
 - Interlocking module already taught-in: teach-in standby is available for approx. 3 min. after switching on
- ➔ Teach-in standby indication, STATE LED flashes 3x repeatedly.
2. Insert the bolt tongue on the handle module during teach-in standby.
 - ➔ The automatic teach-in operation starts (duration approx. 30 s).
During the teach-in operation, the STATE LED flashes (approx. 1 Hz).
Alternate flashing of the STATE and DIA LEDs acknowledges the successful teach-in operation.
Teach-in errors are indicated by the illumination of the red DIA LED and a flashing code of the green STATE LED (see chapter 13. *System status table on page 24*).
3. Switch off operating voltage UB (min. 3 s).
 - ➔ The code of the handle module that was just taught-in is activated in the interlocking module.
4. Switch on operating voltage UB.
 - ➔ The device operates normally.

12.3. Functional check



WARNING

- Danger of fatal injury as a result of faults in installation and the functional check.
- › Before carrying out the functional check, make sure that there are no persons in the danger area.
 - › Observe the valid accident prevention regulations.

12.3.1. Mechanical function test

The bolt tongue on the handle module must slide easily into the actuating head. Close the guard several times to check the function. For devices with mechanical release (emergency release or escape release), the correct function of the release must be checked as well.

12.3.2. Electrical function test

After installation and any fault, the safety function must be fully checked. Proceed as follows:

1. Switch on operating voltage.
 - ➔ The machine must not start automatically.
 - ➔ The interlocking module carries out a self-test. The green STATE LED then flashes at regular intervals.
2. Close all guards.
 - ➔ The machine must not start automatically.
 - ➔ The green STATE LED illuminates continuously.
3. Enable operation in the control system.
4. Open the guard.
 - ➔ The machine must switch off and it must not be possible to start it as long as the guard is open.

Repeat steps 2 - 4 for each guard.

13. System status table

Operating mode	Actuator/door position	Safety outputs F01A and F01B	Door position monitoring output OD	LED indicator Output		State
				STATE (green)	DIA (red) and diagnostic monitoring output OI	
Normal operation	closed	on	on		○	Normal operation, door closed
	open	off	off	1 x	○	Normal operation, door open
Teach-in operation (only unicode)	open	off	off	3 x	○	Device in teach-in standby
	closed	off	on	1 Hz	○	Teach-in operation
	X	off	X	↔		Positive acknowledgment after completion of teach-in operation
Fault display	X	off	X	1 x		Fault in teach-in operation (only unicode). Actuator removed from the actuating range prior to the end of the teach-in operation or faulty actuator detected.
	X	off	off	2 x		Input error Test pulses on the safety outputs cannot be read due to asynchronous test pulses on UB.
	X	off	off	3 x		Read error (e.g. actuator faulty)
	X	off	off	4 x		Output error (e.g. short circuit, loss of switching ability)
	X	off	X	5 x		Disabled actuator detected
	X	off	off	○		Internal fault

Key to symbols	○			LED not illuminated
				LED illuminated
	1 Hz			LED flashes at 1 Hz
	3 x			LED flashes three times, and this is then repeated
	↔			LEDs flash alternately
	X			Any state

After the cause has been remedied, faults can generally be reset by opening and closing the guard. If the fault is still displayed afterward, use the reset function or briefly interrupt the power supply. Please contact the manufacturer if the fault could not be reset after restarting.



Important!

If you do not find the displayed device status in the system status table, this indicates an internal device fault. In this case, you should contact the manufacturer.

14. Technical data



NOTICE

If a data sheet is included with the product, the information on the data sheet applies.

14.1. Technical data for interlocking module MGBS-P-I-AP

Parameter	Value			Unit
	min.	typ.	max.	
General				
Material of interlocking module				
- Head	Die-cast zinc			
- Housing	Reinforced thermoplastic			
Installation position	Any			
Degree of protection	IP67/IP69/IP69K (screwed tight with the related mating connector)			
Safety class acc. to EN IEC 61558	III			
Degree of contamination	3			
Mechanical life	1 x 10 ⁶ operating cycles			
Ambient temperature at UB = 24 V	-20	-	+55	°C
Handle module approach speed, max.	20			m/min.
Actuating/extraction force at 20 °C	10/20			N
Connection	1 plug connector M12, 8-pin			
Operating voltage UB (reverse polarity protected, regulated, residual ripple <5%)	24 ± 15% (PELV)			V DC
Current consumption I _{UB}	40			mA
The following applies to the approval acc. to UL	Operation only with UL Class 2 power supply or equivalent measures			
Switching load acc. to UL	DC 24 V, class 2			
External fuse (operating voltage UB) ¹⁾	0.25	-	8	A
Rated insulation voltage U _i	-	-	50	V
Rated impulse withstand voltage U _{imp}	-	-	0.5	kV
Rated conditional short-circuit current	100			A
Shock and vibration resistance	Acc. to EN IEC 60947-5-3			
EMC protection requirements	Acc. to EN IEC 60947-5-3			
Ready delay	-	-	1	s
Risk time	-	-	260	ms
Turn-on time	-	-	400	ms
Discrepancy time	-	-	10	ms
Test pulse duration	0.35			ms
Frequency band	120 ... 130			kHz
Safety outputs F01A/F01B Semiconductor outputs, p-switching, short circuit-proof				
Output voltage U _{F01A} /U _{F01B} ²⁾				
- HIGH U _{F01A} /U _{F01B}	UB - 1.5	-	UB	V DC
- LOW U _{F01A} /U _{F01B}	0	-	1	
Switching current per safety output	1	-	150	mA
Utilization category acc. to EN IEC 60947-5-2	DC-13 24V 150mA Caution: outputs must be protected with a free-wheeling diode in case of inductive loads			
Switching frequency ³⁾	0.5			Hz
Monitoring outputs OI, OD p-switching, short circuit-proof				
Output voltage	0.8 x UB	-	UB	V DC
Max. load	-	-	50	mA

Parameter	Value			Unit
	min.	typ.	max.	
Characteristics acc. to EN ISO 13849-1				
Category		4		
Performance Level (PL)		e		
PFH		$4.1 \times 10^{-9}/h$		
Mission time		20		years

- 1) Trip characteristic medium slow-blow.
2) Values at a switching current of 50 mA without taking into account the cable lengths.
3) Corresponds to the actuation frequency.

14.1.1. Typical system times

Please refer to the technical data for the exact values.

Ready delay: After switch-on, the device carries out a self-test. The system is ready for operation only after this time.

Turn-on time of safety outputs: The max. reaction time t_{on} is the time from the moment when the guard is closed to the moment when the safety outputs switch on.

Risk time according to EN 60947-5-3: If a handle module moves outside the actuating range, the safety outputs (FO1A and FO1B) are deactivated at the latest after the risk time.

Discrepancy time: The safety outputs (FO1A and FO1B) switch with a slight time offset. They have the same signal state no later than after the discrepancy time.

Test pulses at the safety outputs: The device generates its own test pulses on the safety outputs (FO1A and FO1B). A downstream control system must tolerate these test pulses.

This can usually be set up in the control systems by parameter assignment. If parameter assignment is not possible for your control system or if shorter test pulses are required, please contact our support organization.

The test pulses are output only if the safety outputs are switched on.

14.2. Operating distances

	<p>Important!</p> <ul style="list-style-type: none"> › From the assured release distance S_{ar}, the safety outputs are safely shut down. To achieve the assured release distance S_{ar}, the bolt tongue of the handle module must be pulled completely out of the interlocking module. › To achieve the assured operating distance S_{ao}, the bolt tongue of the handle module must be inserted completely into interlocking module and snap in.
---	---

14.3. Radio frequency approvals

FCC ID: 2AJ58-05

IC: 22052-05



FCC/IC-Requirements

This device complies with part 15 of the FCC Rules and with Industry Canada's licence-exempt RSSs. Operation is subject to the following two conditions:

- 1) This device may not cause harmful interference, and
- 2) this device must accept any interference received, including interference that may cause undesired operation.

Changes or modifications not expressly approved by the party responsible for compliance could void the user's authority to operate the equipment.

NOTE: This equipment has been tested and found to comply with the limits for a Class A digital device, pursuant to part 15 of the FCC Rules. These limits are designed to provide reasonable protection against harmful interference when the equipment is operated in a commercial environment. This equipment generates, uses, and can radiate radio frequency energy and, if not installed and used in accordance with the instruction manual, may cause harmful interference to radio communications.

Operation of this equipment in a residential area is likely to cause harmful interference in which case the user will be required to correct the interference at his own expense.

Le présent appareil est conforme aux CNR d'Industrie Canada applicables aux appareils radio exempts de licence. L'exploitation est autorisée aux deux conditions suivantes :

- (1) l'appareil ne doit pas produire de brouillage, et
- (2) l'utilisateur de l'appareil doit accepter tout brouillage radioélectrique subi, même si le brouillage est susceptible d'en compromettre le fonctionnement.

Supplier's Declaration of Conformity

47 CFR § 2.1077 Compliance Information

Unique Identifier:

MGBS-P-I-AR SERIES
MGBS-P-I1-AR SERIES
MGBS-P-I2-AR SERIES
MGBS-P-IBI-AR SERIES
MGBS-P-L1-AR SERIES
MGBS-P-L2-AR SERIES
MGBS-P-LBI-AR SERIES
MGBS-P-I-AP SERIES
MGBS-P-I1-AP SERIES
MGBS-P-I2-AP SERIES
MGBS-P-IBI-AP SERIES
MGBS-P-L1-AP SERIES
MGBS-P-L2-AP SERIES
MGBS-P-LBI-AP SERIES

Responsible Party – U.S. Contact Information

EUCHNER USA Inc.

1665 N. Penny Lane
Schaumburg
Illinois 60173

+1 315 701-0315
info(at)euchner-usa.com
<http://www.euchner-usa.com>

14.4. Dimension drawings for variants

Plug connector M12

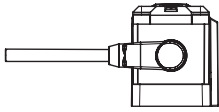

Plug connectors 2 x M12

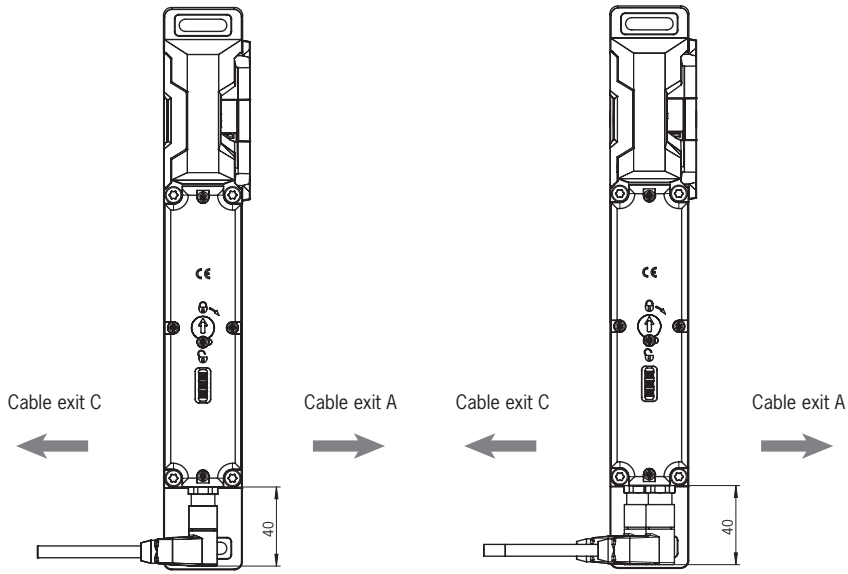
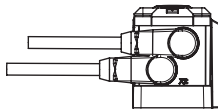

15. Ordering information and accessories



Tip!

Suitable accessories, e.g. cables or assembly material, can be found at www.euchner.com. To order, enter the order number of your item in the search box and open the item view. Accessories that can be combined with the item are listed in *Accessories*.

16. Inspection and service



WARNING

Danger of severe injuries due to the loss of the safety function.

- › If damage or wear is found, the complete interlocking module and handle module must be replaced. Replacement of individual parts or assemblies is not permitted.
- › Check the device for proper function at regular intervals and after every fault. For information about possible time intervals, refer to EN ISO 14119:2025, section 9.2.1.

Regular inspection of the following is necessary to ensure trouble-free long-term operation:

- › Check the switching function (see chapter 12.3. *Functional check on page 23*)
- › Check all additional functions (e.g. escape release, lockout mechanism, etc.)
- › Check the secure mounting of the devices and the connections
- › Check for contamination.

No servicing is required. Repairs to the device are only allowed to be made by the manufacturer.



NOTICE

The year of manufacture is given in the laser marking at the bottom right corner. The current version number in the format (V X.X.X) can also be found on the device.

17. Service

If servicing is required, please contact:

EUCHNER GmbH + Co. KG
Kohlhammerstraße 16
70771 Leinfelden-Echterdingen

Service telephone:
+49 711 7597-500

E-mail:
support@euchner.de

Internet:
www.euchner.com

18. Declaration of conformity

The product complies with the following requirements:

- › Machinery Directive 2006/42/EC (until January 19, 2027)
- › Machinery Regulation (EU) 2023/1230 (from January 20, 2027)

The EU declaration of conformity can be found at www.euchner.com. Enter the order number of your device in the search box. The document is available under *Downloads*.

Euchner GmbH + Co. KG
Kohlhammerstraße 16
70771 Leinfelden-Echterdingen
info@euchner.de
www.euchner.com

Edition:
2527247-04-03/26

Title:
Operating Instructions Safety System MGBS-P-IAP...
(translation of the original operating instructions)

Copyright:
© EUCHNER GmbH + Co. KG, 03/2026

Subject to technical modifications; no responsibility is accepted for the accuracy of this information.