

EUCHNER

Operating Instructions

Key Adapter
MSM-1-K-CKS2BP/BR-FLX-...

EN

Contents

1.	About this document	4
1.1.	Scope.....	4
1.2.	Target group	4
1.3.	Key to symbols.....	4
1.4.	Supplementary documents	4
2.	Correct use	5
3.	Description of the safety function	6
4.	Exclusion of liability and warranty	6
5.	General safety precautions	7
6.	Function	8
6.1.	Monitoring output OA	8
6.2.	Communication connection C	8
6.3.	Switching states	9
7.	Mounting	9
8.	Electrical connection	10
8.1.	Notes on 	11
8.2.	Safety in case of faults.....	11
8.3.	Fuse protection for power supply	11
8.4.	Requirements for connecting cables.....	12
8.5.	Terminal assignment (connection type K)	12
8.6.	Notes on operation with safe control systems.....	13
8.7.	Connection without and with IO-Link communication	13
8.7.1.	Connection without IO-Link communication	13
8.7.2.	Connection with IO-Link communication.....	13
9.	Connection of a single MSM-1-K-CKS2 (separate operation)	14
10.	Connection of several devices in a chain (series connection)	15
10.1.	Series connection with wiring in the control cabinet	16
11.	Using communication data	17
11.1.	Connection to a BR/IO-Link Gateway GWY-CB.....	17
11.2.	Connection to a safety relay ESM-CB.....	17
11.3.	Overview of the communication data	17
11.3.1.	Cyclical data (process data).....	17
11.3.2.	Acyclical data (device data and events).....	18

12.	Setup	19
12.1.	Configuring the device and teaching-in the key for the first time.....	19
12.2.	Teaching-in a new key	20
12.3.	Electrical function test.....	21
13.	Factory reset.....	21
14.	Status and error messages	22
14.1.	LED indicator.....	22
14.2.	Status messages.....	23
14.3.	Error messages.....	24
14.4.	Acknowledging error messages	26
15.	Technical data	27
15.1.	Technical data for key adapter MSM-1-K-CKS2BP/BR-FLX-.....	27
15.1.1.	Radio frequency approvals.....	28
15.1.2.	Typical system times.....	29
15.2.	Technical data for key A-FLX-K-... ..	30
15.2.1.	Dimension drawing for key.....	30
16.	Ordering information and accessories	31
17.	Inspection and service	31
18.	Service	31
19.	Declaration of conformity	31

1. About this document





1.1. Scope

These operating instructions apply to all MSM-1-K-CKS2BP/BR-FLX-... of version 1.0.X. These operating instructions, the document *Safety information* and any available data sheet form the complete user information for your device.

1.2. Target group







Design engineers and installation planners for safety systems on machines, as well as setup and servicing staff possessing special expertise in handling safety components.

1.3. Key to symbols

Symbol/depiction	Meaning
	Printed document
	Document is available for download at www.euchner.com
 DANGER WARNING CAUTION	Safety precautions Danger of death or severe injuries Warning about possible injuries Caution slight injuries possible
 NOTICE Important!	Notice about possible device damage Important information
Tip	Useful information

1.4. Supplementary documents

The overall documentation for this device consists of the following documents:

Document title (document number)	Contents	
Safety information (2525460)	Basic safety information	
Operating instructions (MAN20001779)	(this document)	
Declaration of conformity	Declaration of conformity	
Possibly a data sheet	Item-specific information about deviations or additions	 
	Important! Always read all documents to gain a complete overview of safe installation, setup and use of the device. The documents can be downloaded from www.euchner.com . For this purpose, enter the doc. no. or the order number for the device in the search box.	

2. Correct use

The submodule MSM-1-K-CKS2BP/BR-FLX-... is installed in suitable MGB2...BP/BR or MCM-X system components and used for safe reading and safe evaluation of CKS2 keys. The keys have a high coding level according to EN ISO 14119. Only the keys listed in *Table 1: System components* may be used.

Among other applications, it can be used as part of a key transfer system according to ISO/TS 19837.

Table 1: System components

Key adapter	1 key per packaging unit	Several keys per packaging unit, with identical key code and different key identification
MSM-1-K-CKS2BP-FLX-... MSM-1-K-CKS2BR-FLX-...	A-FLX-K-OA-...	A-FLX-K-OB-...

Before the device is used, a risk assessment must be performed on the machine, e.g. in accordance with the following standards:

- EN ISO 13849-1
- EN ISO 12100
- IEC 62061

Correct use includes observing the relevant requirements for installation and operation, particularly based on the following standards:

- EN ISO 13849-1
- EN 60204-1
- EN ISO 14119

The key adapter must be used only in conjunction with the designated CKS2 keys from EUCHNER. On the impermissible use of different keys, EUCHNER provides no warranty for safe function.

The communication data that can be read via IO-Link must not be used for safety functions.

The user is responsible for the safe overall function, especially for the safe integration into an overall system.

Devices in the version MSM-1-K-CKS2BR can be integrated into a BR device chain. Connection of several devices in a BR series connection is permitted only using devices suitable for this purpose. Check this in the specifications of the device in question.



Important!

- The user is responsible for the proper integration of the device into a safe overall system. For this purpose, the overall system must be validated, e.g. in accordance with EN ISO 13849-1.
- It is only allowed to use components that are permissible according to *Table 1: System components* and *Table 2: Combination options*.

Table 2: Combination options

Submodules	Base units	
	MGB2...BP/BR	MCM-X
MSM-1-K-CKS2BP-FLX-... MSM-1-K-CKS2BR-FLX-...	●	●
Key to symbols	●	Combination possible

3. Description of the safety function

The safety function is defined by the related application.

- › Device safety function:
 - Safe detection of a key belonging to the system and checking the associated key code. The safety outputs are switched on if the key is valid.
- › Safety characteristics: category, Performance Level, PFH (see chapter 15. *Technical data on page 27*).

The following additionally applies in a BR series connection:

- › The safety outputs are switched only when the device receives a corresponding signal from its predecessor in the chain.



NOTICE

You can regard the complete BR device chain as one subsystem during calculation. The following calculation method applies to the PFH value:

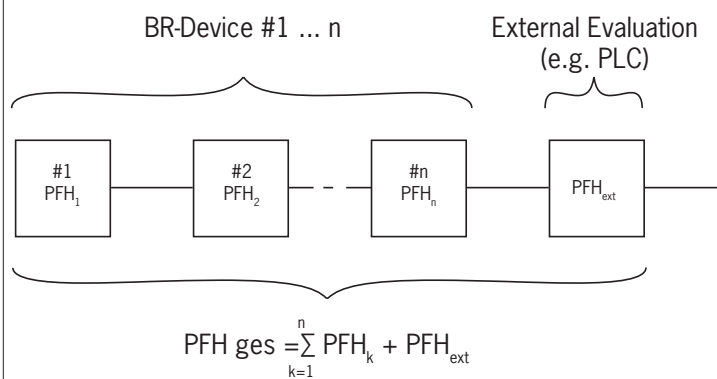

Alternatively, the simplified method according to section 6.2.3 of EN ISO 13849-1:2023 can be used for calculation.

4. Exclusion of liability and warranty

In case of failure to comply with the conditions for correct use stated above, or if the safety regulations are not followed, or if any servicing is not performed as required, liability will be excluded and the warranty void.

5. General safety precautions

Safety components fulfill personnel protection functions. Incorrect installation or tampering can lead to fatal injuries to personnel.

Check the safe function of the device particularly

- › after any setup work
- › after the replacement of a system component
- › after an extended period without use
- › after every fault

Independent of these checks, the safe function of the device should be checked at suitable intervals as part of the maintenance schedule.



DANGER

Danger to life due to selecting the wrong key or tampering.

- › When selecting the key version used, make sure that all measures for risk assessment for the intended application are performed.
- › Unused keys must be rendered unusable or protected against unauthorized access to prevent bypassing of the safety function.
- › If master keys or replacement keys are used, the operating organization must take suitable organizational measures and use a corresponding risk assessment to prevent the system's safety function from being bypassed. For this purpose, observe the information in ISO/TS 19837.



WARNING

Danger to life due to improper installation or due to bypassing (tampering). Safety components fulfill a personnel protection function.

- › Safety components must not be bypassed, turned away, removed or otherwise rendered ineffective. On this topic pay attention in particular to the measures for reducing the possibility of bypassing according to EN ISO 14119:2025, section 8.
- › The switching operation may be triggered only by keys specially designated for this purpose.
- › The key must be completely pulled out of the key adapter in order to switch the safety circuit off safely.
- › Mounting, electrical connection and setup only by authorized personnel possessing the following knowledge:
 - specialist knowledge in handling safety components
 - knowledge about the applicable EMC regulations
 - knowledge about the applicable regulations on operational safety and accident prevention.



Important!

Prior to use, read the operating instructions and the supplementary documents and keep them in a safe place. Ensure the operating instructions are always available during mounting, setup and servicing. For this reason you should archive a printed copy of the operating instructions. You can download the operating instructions from www.euchner.com.

6. Function

Submodule

MSM-1-K-CKS2BP/BR-FLX-...

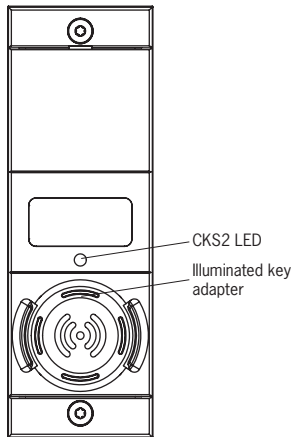

Key A-FLX-K-0A-...

1 key per packaging unit

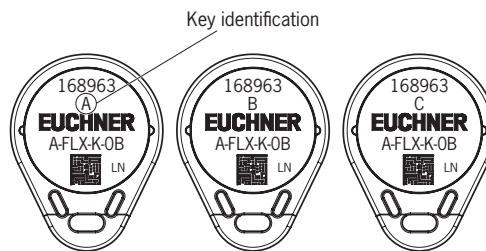

Key A-FLX-K-0B-...

Several keys per packaging unit, with identical key code and different key identification

The submodule has a key adapter with integrated evaluation electronics. The submodule forms a safe system together with a corresponding key. The key determines the function. There is no evaluation of the safety outputs in the base unit used. Evaluation must be implemented outside the base unit in the control system. You will find further information in chapter 12.1. *Configuring the device and teaching-in the key for the first time on page 19.*

The safety outputs are switched on when there is a valid key in the key adapter. The safety outputs are switched off when the key is removed.

A key is valid if its key code was allocated to the key adapter in a teach-in operation, see chapter 12. *Setup on page 19.* Keys of the version A-FLX-K-0A-... are unambiguously allocated to the key adapter in a teach-in operation. For keys of version A-FLX-K-0B-..., the taught-in key and all other keys from the same packaging unit are valid after the teach-in operation because they have the same key code. Only the key version with which the device was configured can be taught-in. A factory reset must be performed to reconfigure the device.

Each key is supplied with a unique electronic code. The high coding level ensures a high level of protection against tampering. The key's code cannot be reprogrammed.

In case of a fault in the key adapter, the safety outputs are switched off and the LED signals a fault (see chapter 14.3. *Error messages on page 24.*)

6.1. Monitoring output OA

Signal OA is present when the device is ready for operation.

6.2. Communication connection C

When the device is connected to a BR/IO-Link Gateway, the monitoring output functions as a communication connection. The key adapter supplies cyclical and acyclical data. You will find an overview of the communication data in chapter 11.3. *Overview of the communication data on page 17.*

6.3. Switching states

	Key in key adapter	Key removed
LED indicator	illuminates green	flashes green slowly
Safety outputs CKS_FO1A and CKS_FO1B	on	off
Signal OA	on	off

7. Mounting



Important!

- › Mounting must be performed only by authorized personnel.
- › The submodule MSM-1-K-CKS2BP/BR-FLX-... can be used only in base units MGB2...BR/BP or MCM-X.
- › Submodule mounting is described in the operating instructions for the respective base unit. Observe the relevant information.

8. Electrical connection

The following connection options are available:

- › Separate operation
- › Series connection with wiring in the control cabinet
- › Series connection with Y-distributors
- › Connection without IO-Link communication
- › Connection with IO-Link communication



WARNING

In the event of a fault, loss of the safety function due to incorrect connection.

- › To ensure safety, both safety outputs must always be evaluated.
- › There is no evaluation of the safety outputs in the base unit used.
- › Monitoring outputs must not be used as safety outputs.
- › Lay the connecting cables with protection to prevent short circuits.



CAUTION

Risk of damage to equipment or malfunctions as a result of incorrect connection.

- › Do not use a control system with pulsing or switch off the pulsing function in your control system. The device generates its own test pulses on the safety outputs. A downstream control system must tolerate these test pulses, which may last up to 0.3 ms. Depending on the inertia of the downstream device (control system, relay, etc.), this can lead to short switching processes. The test pulses are output with the safety outputs switched off only during device start.
- › The inputs on an evaluation unit connected must be positive-switching, as the two outputs on the key adapter deliver a level of +24 V in the switched-on state.
- › All electrical connections must either be isolated from the mains supply by a safety transformer according to IEC 61558-2-6 with limited output voltage in the event of a fault, or by other equivalent insulation measures (PELV).
- › All electrical outputs must have an adequate protective circuit for inductive loads. The outputs must be protected with a free-wheeling diode for this purpose. RC interference suppression units must not be used.
- › Power devices which are a powerful source of interference must be installed in a separate location away from the input and output circuits for signal processing. The cable routing for safety circuits should be as far away as possible from the cables of the power circuits.
- › To prevent EMC interference, the physical environmental and operating conditions at the installation site of the device must comply with the requirements according to the standard EN 60204-1 (EMC).
- › Pay attention to any interference fields from devices such as frequency converters or induction heating systems. Observe the EMC instructions in the manuals from the respective manufacturer.



Important!

If the device does not appear to function when the operating voltage is applied (e.g. LED does not illuminate or flash), it must be returned unopened to EUCHNER.

8.1. Notes on



Important!

- › This device is intended to be used with a Class 2 power source in accordance with UL1310.
- › As an alternative an LV/C (Limited Voltage/Current) power source with the following properties can be used:
 - This device shall be used with a suitable isolating source in conjunction with a fuse in accordance with UL248. The fuse shall be rated max. 3.3 A and be installed in the max. 30 V DC power supply to the device in order to limit the available current to comply with the UL requirements. Please note possibly lower connection ratings for your device (refer to the technical data).
- › For use and application as per the requirements of UL ¹⁾, a connecting cable listed under the UL category code CYJV2 or CYJV must be used.

1) Note on the scope of the UL approval: the devices have been tested as per the requirements of UL508 and CSA/C22.2 no. 14 (protection against electric shock and fire). Only for applications as per NFPA 79 (Industrial Machinery).

8.2. Safety in case of faults

- › The operating voltage U_B is reverse polarity protected.
- › The safety outputs are short circuit-proof.
- › A short circuit between the safety outputs is detected on starting or when the safety outputs are activated by the device.
- › A short circuit in the cable can be excluded by laying the cable with protection.

8.3. Fuse protection for power supply

The power supply must be provided with fuse protection depending on the number of devices and the current required for the outputs. The following rules apply:

Max. current consumption of an individual device I_{max}

$$I_{max} = I_{UB} + I_{OA} + I_{CKS_FO1A+CKS_FO1B}$$

$$I_{UB} = \text{Device operating current (40 mA)}$$

$$I_{OA} = \text{Load current of monitoring output (max. 50 mA)}$$

$$I_{CKS_FO1A+CKS_FO1B} = \text{Load current of safety outputs CKS_FO1A + CKS_FO1B (2 x max. 150 mA)}$$

Max. current consumption of a device chain ΣI_{max}

$$\Sigma I_{max} = I_{CKS_FO1A+CKS_FO1B} + n \times (I_{UB} + I_{OA})$$

$$n = \text{Number of connected devices}$$

8.4. Requirements for connecting cables



CAUTION

Risk of damage to equipment or malfunctions as a result of incorrect connecting cables.

- › Use connection components and connecting cables from EUCHNER.
- › If other connection components are used, the requirements in the following table apply. EUCHNER provides no warranty for safe function in case of failure to comply with these requirements.

Observe the following requirements with respect to the connecting cables:

Parameter	Value		Unit
	M12/8-pin	M12/5-pin	
Recommended cable type	LIYY 8 x 0.34	LIYY 5 x 0.34	mm ²
Cable	8 x 0.34	5 x 0.34	mm ²
Cable resistance R max.	80	80	Ω/km
Inductance L max.	0.65	0.65	mH/km
Capacitance C max.	120	120	nF/km

8.5. Terminal assignment (connection type K)

Wiring diagram		Designation	Function
MCM-X	MGB2	H3_Gn	LED green
X3:2 I/O 3	X2:6 14	H3_Rd	LED red
X2:2 I/O 2	X2:5 13	J3	Teach-in input
X1:2 I/O 1	X2:4 12	OA/C	Status and communication signal
X3:6 I3A	X4:6 30	CKS_FI1X	Safe input, CKS2 key system
X3:4 I3B	X4:7 31	CKS_FO1X	Safe output, CKS2 key system
X3:5 O3A	X3:7 23	UB	Operating voltage 24 V DC
X3:3 O3B	X3:8 24	0 V UB	Ground 0 V DC
X2:6 I2A	X4:1 25		
X1:1 UB	UB 1		
X3:1 OV	OV UB 9		

8.6. Notes on operation with safe control systems

Observe the following guidelines for connection to safe control systems:

- › Use a common power supply for the control system and the connected key adapters.
- › **The following applies to BP devices:** The device tolerates voltage interruptions at UB up to 5 ms in duration, provided that the time between two voltage interruptions is at least 500 ms.
- › **The following applies to BR devices:** A pulsed power supply must not be used for UB. Tap the supply voltage directly from the power supply unit. If the power supply is connected to a terminal of a safe control system, this output must provide sufficient electrical current.
- › Always connect inputs CKS_FI1A and CKS_FI1B directly to a power supply unit or to outputs CKS_FO1A and CKS_FO1B of another EUCHNER BR device (series connection). Pulsed signals must not be present at inputs CKS_FI1A and CKS_FI1B.
- › The safety outputs CKS_FO1A and CKS_FO1B can be connected to the safe inputs of a control system. Prerequisite: the input must be suitable for pulsed safety signals (OSSD signals, e.g. from light grids). The control system must tolerate test pulses on the input signals. This normally can be set up by parameter assignment in the control system. Observe the notes of the control system manufacturer. For the test pulse duration of your key adapter, see chapter 15. *Technical data on page 27.*

A detailed example of connecting and setting the parameters of the control system is available for many devices at www.euchner.com, in the area *Downloads/Applications*. The features of the respective device are dealt with there in greater detail.

8.7. Connection without and with IO-Link communication

8.7.1. Connection without IO-Link communication

Only the safety and monitoring outputs are switched with this connection method.

With a series connection, the safety signals are looped through from device to device.

8.7.2. Connection with IO-Link communication

If, in addition to the safety function, detailed monitoring and diagnostic data are to be processed, a BR/IO-Link Gateway is required.

To poll the communication data from the connected device, communication connection C is routed to the BR/IO-Link Gateway.

You will find further information in the operating instructions for your BR/IO-Link Gateway.

9. Connection of a single MSM-1-K-CKS2 (separate operation)

If a single MSM-1-K-CKS2 is used, connect the device as shown in Fig. 1. The monitoring output OA can be connected to a control system.



WARNING

In the event of a fault, loss of the safety function due to incorrect connection.
 ▶ To ensure safety, both safety outputs CKS_FO1A and CKS_FO1B must always be evaluated.



Important!

The example shows only an excerpt that is relevant for connection of the MSM-1-K-CKS2. The example illustrated here does not show complete system planning. The user is responsible for safe integration into the overall system. Detailed application examples can be found at www.euchner.com. Simply enter the order number of your device in the search box. You will find all available connection examples for the device in *Downloads*.

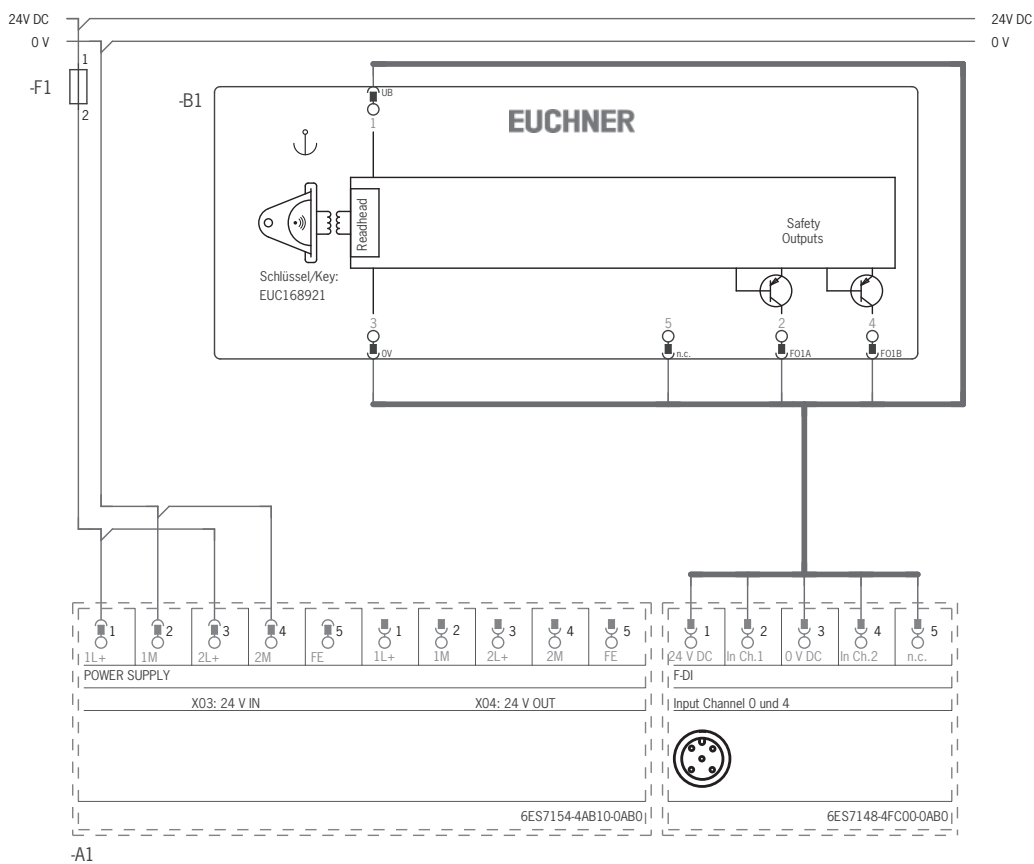

Fig. 1: Connection example for separate operation of an MSM-1-K-CKS2BP/BR-FLX-... on a safe IP67 peripheral module (principle of operation)

10. Connection of several devices in a chain (series connection)



WARNING

In the event of a fault, loss of the safety function due to incorrect connection.

- › To ensure safety, both safety outputs CKS_F01A and CKS_F01B must always be evaluated.



Important!

- › A BR chain may contain a maximum of 20 key adapters.
- › The following connection examples show only excerpts that are relevant for the connection of the MSM-1-K-CKS2. They do not represent complete system planning. The user is responsible for safe integration into the overall system. Detailed application examples can be found at www.euchner.com. Simply enter the order number of your device in the search box. You will find all available connection examples for the device in *Downloads*.

10.1. Series connection with wiring in the control cabinet

The series connection can be implemented via additional terminals in a control cabinet.



Important!

In case of series connection with IO-Link communication:

- The safety outputs are permanently assigned to the respective safety inputs of the downstream key adapter. CKS_FO1A must be routed to CKS_FI1A and CKS_FO1B to CKS_FI1B.
- If the connections are interchanged (e.g. CKS_FO1A to CKS_FI1B), the downstream device will enter the fault state.

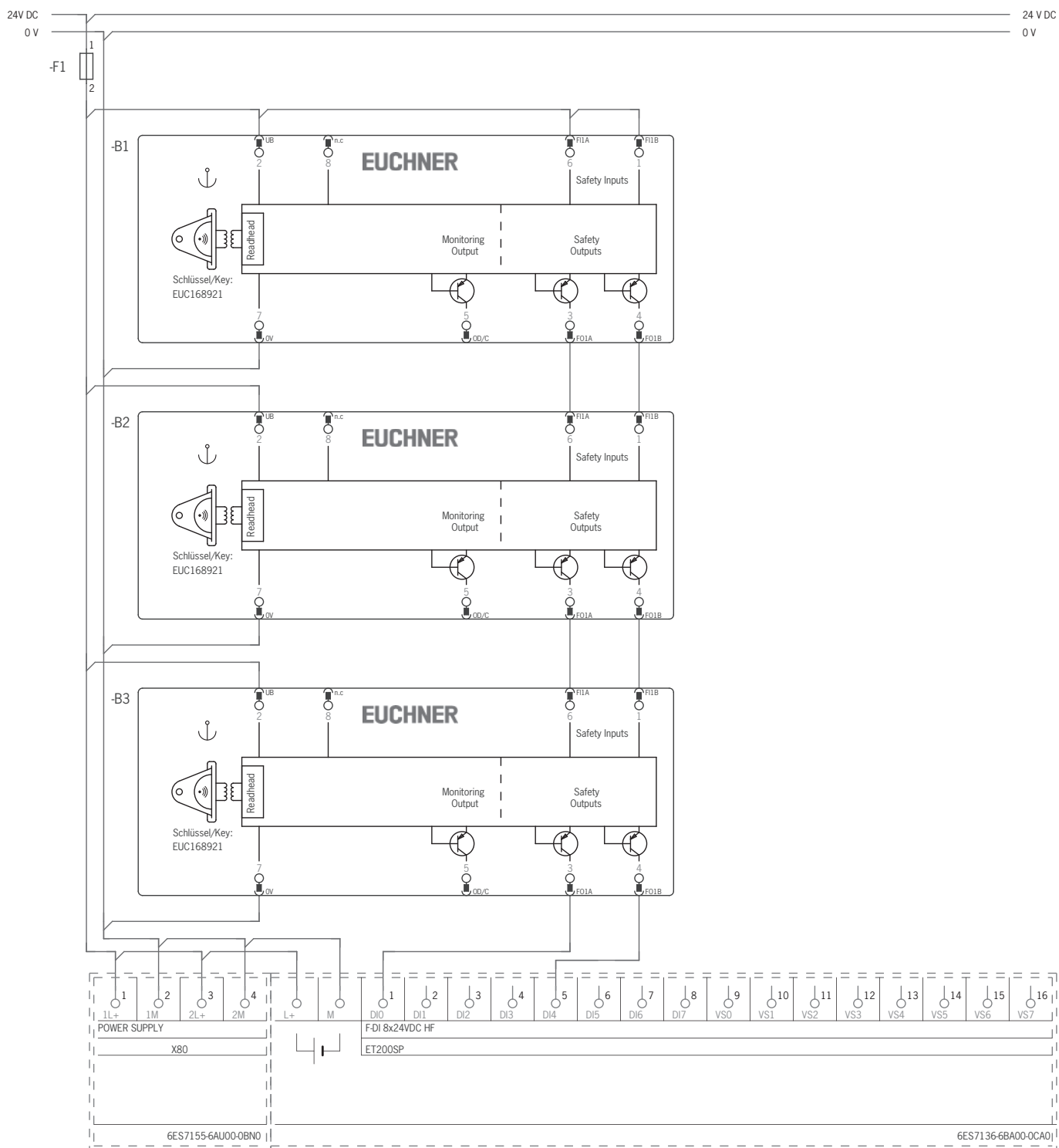

Fig. 2: Connection example for series connection with wiring in the control cabinet (principle of operation)

11. Using communication data

A BR/IO-Link Gateway is required to use the device's communication data and forward them to a higher-level bus system. The following devices are suitable:

- GWY-CB-1-BR-IO (BR/IO-Link Gateway)
- ESM-CB (safety relay with integrated BR/IO-Link Gateway)

11.1. Connection to a BR/IO-Link Gateway GWY-CB

The Gateway is an IO-Link device. Communication via IO-Link offers cyclical (process data) and acyclical (device data and events) data exchange (see chapter 11.3. Overview of the communication data on page 17).

The communication connection C on the device allows the diagnostic line to be connected to the Gateway. The OA/C connection represents a non-safety-related communication channel between the Gateway and the connected devices.

IO-Link communication can be used for the following functions as well:

- Reset for acknowledging error messages

You will find further information in the operating instructions for your BR/IO-Link Gateway.

11.2. Connection to a safety relay ESM-CB

The safety relay ESM-CB features an integrated BR/IO-Link Gateway. In addition to functioning as an IO-Link device (see chapter 11.1. Connection to a BR/IO-Link Gateway GWY-CB on page 17), the device can be used for connecting two monitored single- or dual-channel sensor circuits. The sensor circuits evaluate various signaling devices:

- Sensor circuit S1 with short circuit detection; suitable for single- or dual-channel safety sensors
- Sensor circuit S2, suitable for OSSD signals; short circuit detection by signaling device

When at least one sensor circuit is interrupted, the safety relay initiates the safe state. Different relay starting behaviors and various monitoring functions are possible.

The device's safety outputs CKS_F01A and CKS_F01B are routed to the OSSD inputs of the safety relay. The OA/C connection of the device allows the diagnostic line to be connected to the Gateway.

You will find further information in the operating instructions for your safety relay with integrated BR/IO-Link Gateway.

11.3. Overview of the communication data

The key adapter transmits both process data, which are continuously transmitted to the evaluation unit (cyclical data), and data that can be polled specifically as needed (acyclical data). For further information on connection and on the communication data, refer to the operating instructions for your BR/IO-Link Gateway.

11.3.1. Cyclical data (process data)

Table 3: Cyclical data (process data)

	Bit 7	Bit 6	Bit 5	Bit 4	Bit 3	Bit 2	Bit 1	Bit 0
Byte 1	OI	-	-	-	OM	-	-	OD

Bit	Signal	Message
OI	Diagnostics	There is a fault, see 14.3. Error messages on page 24.
OM	Status	The safety outputs of the device are switched.
OD	Status bit	A valid key is detected in the actuating range.

11.3.2. Acyclical data (device data and events)

After one of the commands listed below is sent, the requested data are provided via the IO-Link Gateway. The reply message always consists of 8 bytes in big endian format.

Example 1: Reply message in response to the command *Send device ID number/serial number*: 06 **02 68 E0 00 01 17 00**

In this example, the device's ID number is **157920** and its serial number is **279**.

Byte number	Byte 0	Byte 1	Byte 2	Byte 3	Byte 4	Byte 5	Byte 6	Byte 7
Reply in hex	06	02	68	E0	00	01	17	00
Description	User data length in bytes	Device ID number			Serial number			Padding data
Reply in dec	6 bytes	157920			279			-

Example 2: Reply message in response to the command *Send current key code*: 05 xx xx **00 5F** xx 00 00

In this example, the device's key code is **95**.

Byte number	Byte 0	Byte 1	Byte 2	Byte 3	Byte 4	Byte 5	Byte 6	Byte 7
Reply in hex	05			00	5F		00	00
Description	User data length in bytes	Current key code			Padding data			
Reply in dec	5 bytes			95			-	-

Command		Reply		
HEX	Meaning	Number of bytes	Bit sequences (big endian format)	
0x02	Send device ID number/serial number	6	Bytes 1 - 3	Device ID number
			Bytes 4 - 6	Serial number
0x03	Send version number of the device	5	Byte 1	{V}
			Bytes 2 - 4	Version number
0x05	Send number of devices in series connection	1		
0x08	Send number of starting processes	3		
0x12	Send current error code	1		
0x13	Send most recently saved error code	1		
0x14	Send size of log file	1		
0x15	Send entry from log file with index	1		
0x16	Send current key code	5	Bytes 3 - 4	Key A-FLX-K-0A-... – 16 bit Key A-FLX-K-0B-... – 10 bit
0x17	Send taught-in key code	5	Bytes 3 - 4	
0x18	Send disabled key code	5	Bytes 3 - 4	
0x19	Send applied voltage in mV	2		
0x0F	Send number of teach-in operations, factory resets and resets for acknowledging error messages	3	Byte 1	Number of teach-in operations
			Byte 2	Number of factory resets
			Byte 3	Number of resets for acknowledging error messages
0x1A	Send current temperature in °C ¹⁾	1		
0x1B	Send number of switching cycles	3		
0x1D	Reset for acknowledging error messages ²⁾	-		
0x1E	Factory reset	1	0x1E – factory reset performed	
0x1F	Send key identification ^{3) 4)}	1	01 – Key identification A	
			02 – Key identification B	
			03 – Key identification C	

1) The read value is the internal operating temperature in the device. This value can exceed the ambient temperature. The device enters the fault state when the internal operating temperature exceeds 80 °C.

2) Each BR device must be addressed individually in a chain.

3) Applies only to the key A-FLX-K-0B-...

4) With different packaging units, the key identification is always the same.

For more information on these and other acyclical data, refer to the operating instructions for your BR/IO-Link Gateway.

12. Setup



DANGER

Danger to life due to tampering.

- › Unused keys must be rendered unusable or protected against unauthorized access to prevent bypassing of the safety function.
- › If master keys or replacement keys are used, the operating organization must take suitable organizational measures and use a corresponding risk assessment to prevent the system's safety function from being bypassed. For this purpose, observe the information in ISO/TS 19837.

12.1. Configuring the device and teaching-in the key for the first time

The device must be configured and the key must be allocated to the key adapter before the system forms a functional unit. The function is defined during configuration using the key. Configuration and the teach-in operation occur simultaneously in the delivery state or after a factory reset.

Key	Function
A-FLX-K-0A-...	1 key per packaging unit
A-FLX-K-0B-...	Several keys per packaging unit, with identical key code and different key identification



WARNING

Danger to life due to improper use

- › During the initial configuration or reconfiguration after a factory reset, ensure that all risk assessment measures for the selected function were performed.



Important!

- › If the key to be taught-in is in the key adapter for less than 30 s, the device will not be configured and the key will not be activated.
- › Incorrect wiring at the safety inputs or safety outputs will be ignored on initial configuration or reconfiguration.
- › For keys of version A-FLX-K-0B-...: Only one key per packaging unit has to be taught-in. All other keys from the same package can be used without an additional teach-in operation.

Prerequisite:

- › The device is in the delivery state. A factory reset must be performed before a preconfigured device can be reconfigured (see chapter 13. *Factory reset on page 21*).
- › The device is isolated from the operating voltage.

1. Make sure that no key is inserted.
2. Connect operating voltage to the key adapter.
 - ➔ The LED flashes white quickly. The device carries out a self-test.
 - ➔ The LED flashes white slowly. The device is in unlimited teach-in standby.
3. Insert a key.
 - ➔ The teach-in operation begins. The LED alternately flashes white/violet slowly.
 - ➔ The teach-in operation ends after approx. 30 s. The LED alternately flashes green/blue quickly (approx. 3 Hz).
4. Switch off operating voltage for at least 3 s.
 - ➔ The code of the taught-in key is activated in the key adapter. The key is valid.
5. Switch on operating voltage.
 - ➔ The device operates normally.

12.2. Teaching-in a new key



Important!

- › The teach-in operation may be performed only if the device functions flawlessly. The LED flashes green slowly.
- › Only the key version with which the device was configured can be taught-in. To reconfigure the device, see chapter 12.1. *Configuring the device and teaching-in the key for the first time on page 19.*
- › During a teach-in operation, the safety outputs are switched off, i.e. the system is in the safe state.
- › The key adapter disables the code of the previous key if teach-in is carried out for a new key. Teach-in is not possible again immediately for this device if a new teach-in operation is carried out. The disabled code is released again in the key adapter only after a third code has been taught-in.
- › The key adapter can be operated only with the last key taught-in.
- › The number of teach-in operations is unlimited.
- › If the key adapter detects the most recently taught-in key during teach-in standby, the teach-in operation will be continued and completed with positive acknowledgment. The LED alternately flashes green/blue quickly. Follow steps 5 and 6 to change to normal operation.
- › If the key to be taught-in is within the key adapter for less than 30 s, it will not be activated and the most recently taught-in key will remain saved.
- › In normal mode, it is not possible to start a teach-in operation by pressing the pushbutton.
- › For keys of version A-FLX-K-OB-...: Only one key per packaging unit has to be taught-in. All other keys from the same package can be used without an additional teach-in operation.

Prerequisite:

- › The device is isolated from the operating voltage.
1. Make sure that no key is inserted.
 2. Connect operating voltage to the key adapter.
 - ➔ Only with BR device: The LED flashes white quickly (3 Hz). The device carries out a self-test.
 - ➔ The LED flashes green slowly. The device is ready for operation.
 3. Apply voltage of 24 V to input J3 within 3 min.
 - ➔ The device is in teach-in standby for up to 3 min. The LED illuminates white.
 4. Insert a non-taught-in key.
 - ➔ The teach-in operation begins. The LED alternately flashes white/violet slowly.
 - ➔ The teach-in operation ends after approx. 30 s. The LED alternately flashes green/blue quickly (approx. 3 Hz).
 5. Switch off operating voltage for at least 3 s.
 - ➔ The code of the newly taught-in key is activated in the key adapter. The key is valid.
 6. Switch on operating voltage.
 - ➔ The device operates normally.

12.3. Electrical function test



WARNING

Danger of fatal injury as a result of faults in installation and the functional check.

- › Before carrying out the functional check, make sure that there are no persons in the danger area.
- › Observe the valid accident prevention regulations.

After installation and after any fault, the safety function must be fully checked. Proceed as follows:

1. Switch on operating voltage.
 - ➔ The machine must not start automatically.
 - ➔ The key adapter carries out a self-test. The LED then flashes green slowly.
2. Insert key.
 - ➔ The LED illuminates green.
3. Enable operation in the control system.
4. Remove key.
 - ➔ The machine must switch off and it must not be possible to start it as long as a key is not inserted.
 - ➔ The LED flashes green slowly.

Repeat steps 2 ... 4 for each key adapter.

13. Factory reset

A factory reset deletes the configuration and restores the device's factory settings.

To perform a factory reset, connect the two outputs CKS_FO1A and CKS_FO1B to 0 V before connecting the operating voltage or send the command 0x1E via IO-Link communication (see chapter 11.3.2. *Acyclical data (device data and events) on page 18*).

14. Status and error messages

14.1. LED indicator

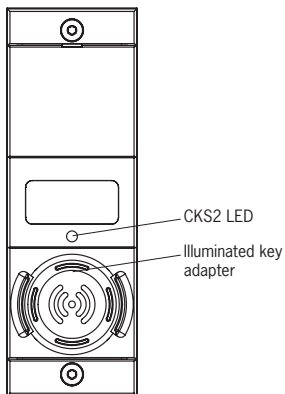

LED	Color
CKS2	RGB
Illuminated key adapter	red, green, yellow (externally controlled)











Important!









If you do not find the displayed device status in the following tables, this indicates an internal device fault. Contact the EUCHNER support team.

Key to symbols			LED not illuminated
			LED illuminated
	quickly		LED flashes quickly (3 Hz)
	slowly		LED flashes slowly (0.6 Hz)
			LED flashes alternately
	X		Any state





14.2. Status messages

Operating mode	LED indicator	Safety outputs CKS_F01A / CKS_F01B	Monitoring output OA signal	Status
Self-test	 white quickly 3 Hz (only for MSM-1-K-CKS2BR: 5 s)	off	off	Self-test after operating voltage is switched on.
	 green quickly			No communication with the BR/IO-Link Gateway.
Normal operation	 green slowly	off	off	Device is ready for operation. No key inserted.
	 green	on	on	Key inserted. The safety outputs of the preceding device in a series connection are switched on.
	 green/orange slowly	off	on	Key inserted. The safety outputs of the preceding device in a series connection are switched off.
Teach-in operation	 white	off	off	Device is in teach-in standby (see chapter 12.2. <i>Teaching-in a new key on page 20</i>).
	 white/violet slowly		on	Teach-in operation
	 green/blue quickly		off	Positive acknowledgment after successful teach-in operation.
Factory reset	 white/blue quickly	off	off	Factory reset
Error	depending on the error	off	depending on the error	Error message (see chapter 14.3. <i>Error messages on page 24</i>)

14.3. Error messages

Error code via IO-Link	LED indicator	Error	Troubleshooting	Acknowledging errors	
				Remove key for 2 s	Reset
Teach-in errors					
0x1F	 white/red slowly	No key detected during teach-in standby.	The key must be inserted within 3 minutes of the pushbutton being pressed.		●
		Key removed from the key adapter prior to the end of the teach-in operation.	Repeat teach-in operation.		●
0x28		The pushbutton was pressed for too long.	Press the pushbutton for no longer than 30 s.		●
0x25	 blue quickly	Disabled key detected during the teach-in operation: The key was taught-in during the penultimate teach-in operation and is disabled for the current teach-in operation.	Repeat teach-in operation with a new key (see chapter 12.2. <i>Teaching-in a new key on page 20</i>).		●
0x42	 blue slowly	Invalid key detected: The key is not intended for the current device configuration.	<ul style="list-style-type: none"> › Perform the teach-in operation with a key intended for the current device configuration. › If the device is to be reconfigured, observe chapter 12.1. <i>Configuring the device and teaching-in the key for the first time on page 19</i>. 		●
0x45	 blue	Faulty or incompatible key detected: The key's data structure cannot be read. The key is faulty or is not suitable for the device.	Repeat teach-in operation with a new key.		●
Input errors					
0x2E	 violet slowly	Different signal states at the safety inputs CKS_F1A and CKS_F1B during operation.	<ul style="list-style-type: none"> › Check wiring. › Check preceding device in the chain. 	●	
0x30		Different signal states at the safety inputs CKS_F1A and CKS_F1B during the self-test.	Check wiring.		●
0x31 0x32		<ul style="list-style-type: none"> › Test pulses not detected at safety input CKS_F1A or CKS_F1B during operation. › With a single device or the first switch in the switch chain: different signal states detected at safety inputs CKS_F1A and CKS_F1B during operation. 		●	
Transponder/read errors					
0x44 ¹⁾	 blue slowly	Invalid key detected during operation: The key is not intended for the current device configuration.	Use a valid key.	●	
0x46 ¹⁾	 blue	Faulty or incompatible key detected during operation: The key's data structure cannot be read. The key is faulty or is not suitable for the device.		●	
0x47 ¹⁾	 blue quickly	Disabled key detected during operation: The key is not the currently valid key.		●	
0x48 ¹⁾	 white/blue slowly	Non-taught-in key detected during operation.		<ul style="list-style-type: none"> › Use the currently valid key. › Teach-in the key. 	●

1) The error code is not saved internally. It can be read as long as the respective key is inserted.

Error code via IO-Link	LED indicator	Error	Troubleshooting	Acknowledging errors	
				Remove key for 2 s	Reset
Output errors					
0x4C 0x4D	 violet quickly	A short circuit or ground fault is detected at safety output CKS_F01A or CKS_F01B during the self-test.	Check wiring.		●
0x54		A short circuit or ground fault is detected at safety output CKS_F01A or CKS_F01B during operation.		●	
Environment errors					
0x60	 orange/red slowly	Supply voltage too high.	Decrease supply voltage.	●	
0x61		Supply voltage too low.	<ul style="list-style-type: none"> › Increase supply voltage. › Check system configuration: cable length, number of devices in the switch chain. 	●	
0x62	 orange/red quickly	Device temperature too high.	<ul style="list-style-type: none"> › Observe the specified temperature range, see chapter 15. <i>Technical data on page 27.</i> 		●
0x63		Device temperature too low.			
Internal fault					
0x01	 red	In case of series connection with IO-Link communication: Safety input CKS_F11A is routed to safety output CKS_F01B of the previous device.	Check wiring.		●
		<ul style="list-style-type: none"> › Internal device fault › Supply voltage extremely high or extremely low. › Device temperature extremely high or extremely low. 	<ul style="list-style-type: none"> › Check supply voltage. › Check device temperature. › Restart the device. On repeated occurrence, contact the EUCHNER support team. 		●
		A short circuit is detected at safety outputs CKS_F01A and CKS_F01B during the self-test or during operation.	Check wiring.		●

14.4. Acknowledging error messages

Depending on the error type, the error message can be acknowledged by briefly removing the key or by a reset.

The reset can be performed as follows.

Reset	Centrally for all devices in a chain	Each device must be addressed individually	Further information
By briefly disconnecting the power supply	●	-	-
Via the cyclical data of IO-Link communication	●	-	See operating instructions for the IO-Link Gateway
Via the acyclical data of IO-Link communication	-	●	See chapter 11.3.2. <i>Acyclical data (device data and events)</i> on page 18

Reset for acknowledging error messages does not delete the configuration.



Important!

Contact the EUCHNER support team if the fault display is not reset after briefly disconnecting the power supply.

15. Technical data



NOTICE

If a data sheet is available for the product, the information on the data sheet applies.

15.1. Technical data for key adapter MSM-1-K-CKS2BP/BR-FLX-...

Parameter	Value			Unit
	min.	typ.	max.	
Housing material	Fiber glass reinforced plastic			
Dimensions	See data sheet dimension drawing			mm
Weight (device without connecting cable)	0.08			kg
Ambient temperature at $U_B = 24$ V DC	-25	-	+55	°C
Storage temperature	-30	-	+70	
Degree of protection	IP65 ¹⁾ (IP20)			
Safety class	III			
Degree of contamination	2			
Installation position	Any			
Operating voltage U_B	24 -15/+20%, regulated, residual ripple < 5% (PELV)			V DC
Current consumption	40			mA
External fuse (operating voltage)	0.25	-	8	A
Safety outputs CKS_F01A/CKS_F01B	Semiconductor outputs, p-switching, short circuit-proof			
- Output voltage $U_{CKS_FO1A}/U_{CKS_FO1B}$ ²⁾				
HIGH U_{CKS_FO1A}	$U_B/4$	-	U_B	V DC
HIGH U_{CKS_FO1B}				
LOW $U_{CKS_FO1A}/U_{CKS_FO1B}$	0		1	
Switching current per safety output	1	-	150	mA
Utilization category	DC-13 24 V 150 mA Caution: outputs must be protected with a free-wheeling diode in case of inductive loads.			
Off-state current I_r	≤ 0.25			mA
Door position monitoring output OA/C ²⁾	p-switching, short circuit-proof			
- Output voltage				
HIGH	$U_B/1.5$	-	U_B	V DC
LOW	0	-	1	
- Switching current	1	-	50	mA
Rated insulation voltage U_i	-	-	300	V
Rated impulse withstand voltage U_{imp}	-	-	1.5	kV
Conditional short-circuit current	100			A
Shock and vibration resistance	Acc. to EN 60947-5-3			
EMC protection requirements	Acc. to EN 60947-5-3			
Ready delay	-	MSM-1-K-CKS2BP: 2 MSM-1-K-CKS2BR: 5	-	s
Risk time acc. to EN 60947-5-3	-	-	125	ms
Risk time acc. to EN 60947-5-3, extension for each additional device	-	-	10	ms
Reaction time ³⁾	27.4			ms
Reaction time extension	6.7			ms
Turn-on time	-	-	400	ms
Discrepancy time	-	-	10	ms
Test pulse duration	-	-	0.3	ms
Test pulse interval	96	-	-	ms
Characteristics acc. to EN ISO 13849-1 and EN IEC 62061				
Category	4			
Performance Level	PL e			
PFH	$4.11 \times 10^{-9} / h$			
Mission time	20			years
Maximum SIL	3			

1) IP65 only in the screwed tight state with the specified base units.

2) Values at a switching current of 50 mA without taking into account the cable lengths.

3) The reaction time is the time until the moment when at least one of the outputs (CKS_F01A or CKS_F01B) switches off when the key is removed from the actuating range, given compliance with all manufacturer's specifications.

15.1.1. Radio frequency approvals

FCC ID: 2AJ58-20

IC: 22052-20

FCC/IC-Requirements

This device complies with part 15 of the FCC Rules and with Industry Canada's licence-exempt RSSs. Operation is subject to the following two conditions:

- 1) This device may not cause harmful interference, and
- 2) this device must accept any interference received, including interference that may cause undesired operation.

Changes or modifications not expressly approved by the party responsible for compliance could void the user's authority to operate the equipment.

NOTE: This equipment has been tested and found to comply with the limits for a Class A digital device, pursuant to part 15 of the FCC Rules. These limits are designed to provide reasonable protection against harmful interference when the equipment is operated in a commercial environment. This equipment generates, uses, and can radiate radio frequency energy and, if not installed and used in accordance with the instruction manual, may cause harmful interference to radio communications. Operation of this equipment in a residential area is likely to cause harmful interference in which case the user will be required to correct the interference at his own expense.

Le présent appareil est conforme aux CNR d'Industrie Canada applicables aux appareils radio exempts de licence. L'exploitation est autorisée aux deux conditions suivantes :

- (1) l'appareil ne doit pas produire de brouillage, et
- (2) l'utilisateur de l'appareil doit accepter tout brouillage radioélectrique subi, même si le brouillage est susceptible d'en compromettre le fonctionnement.

Unique Identifier:

MSM-1-R-CKS2 Series
MSM-1-R-CKS2BP Series
MSM-1-R-CKS2BR Series
MSM-1-K-CKS2 Series
MSM-1-K-CKS2BP Series
MSM-1-K-CKS2BR Series

U.S. Contact Information

EUCHNER USA Inc.
1860 Jarvis Avenue
Elk Grove Village, Illinois 60007
+1 315 701-0315
info(at)euchner-usa.com
<http://www.euchner-usa.com>

15.1.2. Typical system times

Refer to the technical data for the exact values.

Ready delay: After switch-on, the device carries out a self-test. The system is ready for operation only after this time.

Turn-on time of safety outputs: The max. reaction time t_{on} is the time from the moment when the key is in the actuating range to the moment when the safety outputs switch on.

Simultaneity monitoring of safety inputs CKS_FI1A/CKS_FI1B: If the safety inputs have different switching states over a certain time, the safety outputs CKS_FO1A and CKS_FO1B will be switched off. The device enters the fault state.

Risk time according to EN 60947-5-3: The risk time is the maximum time until at least one of the safety outputs CKS_FO1A or CKS_FO1B switches off safely when the key is removed from the actuating range. This also applies if an internal or external fault occurs at this moment.

If several devices are operated in a series connection, the risk time of the overall device chain will increase with each device added. Use the following calculation formula:

$$t_r = t_{r,e} + (n \times t_i)$$

t_r = Total risk time

$t_{r,e}$ = Risk time for single device (see technical data)

t_i = Risk time extension per device

n = Number of additional devices (total number -1)

Discrepancy time: The safety outputs CKS_FO1A and CKS_FO1B switch with a slight time offset. They have the same signal state no later than after the discrepancy time.

Test pulses at the safety outputs: The device generates its own test pulses on the safety outputs CKS_FO1A and CKS_FO1B. A downstream control system must tolerate these test pulses.

This can usually be set up in the control systems by parameter assignment. If parameter assignment is not possible for your control system or if shorter test pulses are required, contact our support organization.

15.2. Technical data for key A-FLX-K-...

Parameter	Value			Unit
	min.	typ.	max.	
Housing material	ABS plastic			
Dimensions	40 x 31 x 5			mm
Weight	0.004			kg
Ambient temperature	-30	-	+70	°C
Degree of protection	IP65/IP67			
Power supply	Inductive via key adapter			

15.2.1. Dimension drawing for key

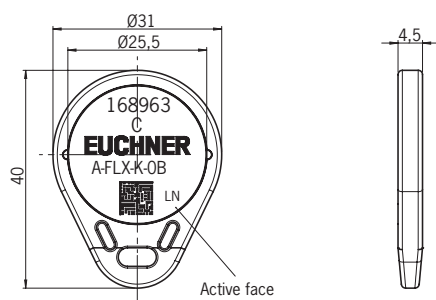

16. Ordering information and accessories



Tip!

Suitable accessories, e.g. cables or assembly material, can be found at www.euchner.com. To order, enter the order number of your item in the search box and open the item view. Accessories that can be combined with the item are listed in *Accessories*.

17. Inspection and service



WARNING

Loss of the safety function because of damage to the device.

- › In case of damage, the entire device must be replaced.
- › Only accessories or spare parts that can be ordered from EUCHNER may be replaced.

Regular inspection of the following is necessary to ensure trouble-free long-term operation:

- › Check the switching function (see chapter 12.3. *Electrical function test on page 21*)
- › Check the secure mounting of the devices and the connections
- › Check for contamination

No servicing is required. Repairs to the device are only allowed to be made by EUCHNER.



NOTICE

The year of manufacture can be seen in the bottom right corner. The current version number in the format (VX.X.X) can also be found on the device.

18. Service

If servicing is required, please contact:

EUCHNER GmbH + Co. KG
Kohlhammerstraße 16
70771 Leinfelden-Echterdingen
Germany

Service telephone:

+49 711 7597-500

E-mail:

support@euchner.de

Internet:

www.euchner.com

19. Declaration of conformity

The product complies with the requirements according to

- › Machinery Directive 2006/42/EC (until January 19, 2027)
- › Machinery Regulation (EU) 2023/1230 (from January 20, 2027)
- › Explosion Protection Directive (ATEX) 2014/34/EU

The EU declaration of conformity can be found at www.euchner.com. Enter the order number of your device in the search box. The document is available under *Downloads*.

EUCHNER GmbH + Co. KG
Kohlhammerstraße 16
70771 Leinfelden-Echterdingen
Germany
info@euchner.de
www.euchner.com

Edition:
MAN20001779-01-03/25
Title:
Operating Instructions Key Adapter
MSM-1-K-CKS2BP/BR-FLX-...
(translation of the original operating instructions)
Copyright:
© EUCHNER GmbH + Co. KG, 03/2025

Subject to technical modifications; no responsibility is accepted for the accuracy of this information.