

## Scope





These operating instructions are valid for all ZSA/ZSR. These operating instructions, the document *Safety information* and any available data sheet form the complete user information for your device.

### Important!

Make sure to use the operating instructions valid for your product version. The version numbers can be found on the type label of your product. Please contact the EUCHNER service team if you have any questions.

## Supplementary documents

The overall documentation for this device consists of the following documents:

Document title (document number)	Contents	
Safety information (2525460)	Basic safety information	
Operating instructions (2092781)	(this document)	
Declaration of conformity	Declaration of conformity	
Any additions to the operating instructions	Take any associated additions to the operating instructions or data sheets into account.	

### Important!

Always read all documents to gain a complete overview of safe installation, setup and use of the device. The documents can be downloaded from [www.euchner.com](http://www.euchner.com). For this purpose, enter the doc. no. or the order number for the device in the search box.

## Correct use

The enabling switches described are manually operated command switches that make it possible to work in the danger area of machines and installations.

Enabling switches represent part of a safety-related control system according to EN ISO 13849-1 or EN 62061 and fulfill a safety function. In conjunction with other safety functions, e.g. *SLS = Safely Limited Speed according to EN 61800-5-2*, the enabling switches can be used as part of an enabling system according to EN ISO 12100 for working with open guards or switched-off guards. The various safeguards must be activated via a control and operating mode selector that can be locked in every position or via an equivalent device.

### Three-stage ZSA2.../ZSR2...

The device possesses a three-position enabling switch according to EN 60947-5-8 or is a device for enabling control with three positions according to EN 60204-1. A dangerous movement is only allowed to be enabled in position 2 (center position). Authorized operating personnel can then enter the danger area, e.g.:

- ▶ for setting up
- ▶ for observing work sequences
- ▶ for maintenance.

### Two-stage ZSA1...

The device is used for enabling control with two positions according to EN 60204-1. A dangerous movement is only allowed to be enabled in position 2. Authorized operating personnel can then enter the danger area, e.g.:

- ▶ for setting up
- ▶ for observing work sequences
- ▶ for maintenance.

Before the device is used, a risk assessment must be performed on the machine, e.g. in accordance with the following standards:

- ▶ EN ISO 13849-1
- ▶ EN ISO 12100
- ▶ EN IEC 62061

Correct use includes observing the relevant requirements for installation and operation, particularly based on the following standards:

- ▶ EN ISO 13849-1
- ▶ EN IEC 60204-1
- ▶ EN IEC 62061

### Important!

- ▶ The user is responsible for the integration of the device in a safe overall system. For this purpose, the overall system must be validated, e.g. in accordance with EN ISO 13849-1.
- ▶ The enabling switch user must assess and document remaining risks.
- ▶ If a data sheet is included with the product, the information on the data sheet applies in case of discrepancies with the operating instructions.

## Description of the safety function

If 2-channel evaluation of the enabling switch is used with monitoring for same contact state or antivalent contact state, category 3 as per EN ISO 13849-1 can be achieved.

Devices from this series feature the following safety function:

### Enable control (manually activated interlocking function in a control system according to EN 60204-1)

Safety function:

- ▶ If the enabling switch is not pressed (position 1), at least one of the contacts is open.
- ▶ If the enabling switch is pressed all the way down (position 3), at least one of the contacts is open (only three-stage ZSA2.../ZSR2...).

Safety characteristic:

- ▶ B<sub>10D</sub> (see section *Technical data*).

Depending on version, other functions may be possible, such as LEDs. These must not be used as part of a safety function.

## Exclusion of liability and warranty

In case of failure to comply with the conditions for correct use stated above, or if the safety regulations are not followed, or if any servicing is not performed as required, liability will be excluded and the warranty void.

## General safety precautions

Enabling switches fulfill personnel protection functions. Incorrect installation or tampering can lead to fatal injuries to personnel.

- Check the safe function of the guard particularly
- ▶ after any setup work
  - ▶ after the replacement of a system component
  - ▶ after an extended period without use
  - ▶ after every fault.

Independent of these checks, the safe function of the guard should be checked at suitable intervals as part of the maintenance schedule.

- ▶ No commands for potentially hazardous conditions are allowed to be initiated with the enabling switch alone.
- ▶ The safety function of enabling switches must not be bypassed (bridging of contacts), tampered with or otherwise rendered ineffective.

- ▶ The enabling switch must be protected against attempts by the operator to bypass its function.
- ▶ Enabling switches may be used only by authorized persons who can recognize hazards in time and who are able to take appropriate action immediately.
- ▶ Every person present in the danger area must carry their own enabling switch on their person.
- ▶ Mounting, electrical connection and setup only by authorized personnel.

In the event of malfunctions or damage, the enabling switch must be replaced. The device may be repaired only by the manufacturer.

### Important!

Prior to use, read the operating instructions and keep these in a safe place. Ensure the operating instructions are always available during mounting, setup and servicing. You should archive a printed copy of the operating instructions. You can download the operating instructions from [www.euchner.com](http://www.euchner.com).

## Function

Enabling switches are used as a manual interlocking device for a control system (enable control). In position 2, the enabling switch permits machine operation with separate start control. In position 1 and in position 3, a stop function must be initiated by the machine control and machine operation prevented.

### Three-stage ZSA2.../ZSR2...

- ▶ Position 1: Off function, pushbutton not pressed
- ▶ Position 2: Enabling function (ON), pushbutton pressed to center position (actuating point)
- ▶ Position 3: Off function, pushbutton pressed to end stop

The enabling function is canceled by releasing the pushbutton or pressing it beyond the actuating point. The enabling function does not become effective when position 2 is passed during the return from position 3 to position 1.

For information on the functions of the various versions, see Fig. 1.

### Two-stage ZSA1...

#### WARNING

Danger of severe injuries due to incorrect use.

- ▶ The ZSA1 switch must not be used in safety circuits.

- ▶ Position 1: Off function, pushbutton not pressed
- ▶ Position 2: enabling function, pushbutton pressed to end stop

The enabling function is removed by releasing the pushbutton. For information on the functions of the various versions, see Fig. 1.

## Mounting

A suitable holder must be used for enabling switches. You will find corresponding accessories at [www.euchner.com](http://www.euchner.com).

## Electrical connection

### **⚠ WARNING**

There will be no safety function if the device is installed or connected incorrectly. This situation can result in serious accidents and injuries or even death.

- ▶ Installation and electrical connection must be performed only by qualified personnel.
- ▶ All electrical outputs must have an adequate protective circuit for inductive loads. The outputs must be protected with a free-wheeling diode for this purpose. RC interference suppression units must not be used.

Please pay attention to the overdimensioning of the electrical contacts in relation to the load.

## Connecting enabling switch

### Selecting contacts or contact combinations

Always use a dual-channel, safe input to connect an enabling switch to a safety evaluation unit. Use the recommended contact combinations (for example, see Fig. 1).

If you use your own contact combination, please pay attention to the following notes:

Connect the enabling switch such that

- ▶ Two independent switching contacts or contact combinations are used.
- ▶ The switching contacts or contact combinations are either antivalent (one normally open contact and one normally closed contact) or equivalent (two normally closed contacts or two normally open contacts).

The parameters for this connection must be configured in the safe evaluation unit to suit the switching contacts chosen and their wiring. For this purpose, use the appropriate parameters:

- ▶ Dual-channel equivalent evaluation

Both contacts are closed at the same time in the enabling position (position 2)

- ▶ Dual-channel antivalent evaluation

One contact is open in the enabling position (position 2), the second closed.

- ▶ Discrepancy time

Activate the discrepancy monitoring. Because the two contacts never switch exactly simultaneously, you must specify a time within which simultaneity applies. A time of 3 s has proven appropriate for electromechanical contacts.

- ▶ Resetting after fault detection

Select the parameter such that, after a fault, the enabling switch is automatically reset if both contacts were in the open position (for equivalent contacts) or one contact was open and the other closed (for antivalent contacts) and they are then placed again in the correct position for enabling. This can be achieved by releasing the enabling switch and pressing it again.

This automatic reset is important above all if an enabling switch is to be used for an extended period. Often position 2 (enabling) is left only a little due to fatigue of the operator's hand or thumb. In this situation, only one of the contacts signals a release; the other remains in the enabling position. The control system interprets this situation as an enabling switch fault. Now it is helpful if it is possible to continue working by simply releasing and pressing again.

Should this not be possible, to some extent the fault can also be automatically acknowledged by the control system by means of the programming. In any case, please ensure that release is detected unambiguously first (both contacts in position 1 again) to rule out any faults in the wiring!

Hazards due to crushing or cutting of the connecting cable must be prevented by suitable measures. These include:

- ▶ Protection of the connecting cable against impermissible loads (e.g. crushing, shearing) by means of suitable laying.
- ▶ Use of an evaluation unit that makes it possible to monitor for short circuits and the simultaneity of the channels.
- ▶ Use of cables with individually screened cores. These screens are to be connected to the machine's earthing system so that cable short circuits can be detected and the control system shut down immediately by the triggering of the short circuit protection.

## Notes about UL

This device is intended to be used with a Class 2 power source in accordance with UL1310.

As an alternative an LV/C (Limited Voltage/Current) power source with the following properties can be used:

- ▶ This device shall be used with a suitable isolating source in conjunction with a fuse in accordance with UL248. The fuse shall be rated max. 3.3 A and be installed in the max. 30 V DC power supply to the device in order to limit the available current to comply with the UL requirements. Please note possibly lower connection ratings for your device (refer to the technical data).

## Functional check

### **⚠ WARNING**

Danger of fatal injury as a result of faults in installation and the functional check.

- ▶ Before carrying out the functional check, make sure that there are no persons in the danger area.
- ▶ Observe the valid accident prevention regulations.

Check the enabling switch by means of a functional check (enabling only in position 2). Check that there is no enabling function in position 2 after reaching position 3 and releasing again.

Depending on version: check the integrated functions, such as LEDs, etc.

## Inspection and service

### **⚠ WARNING**

Danger of severe injuries due to the loss of the safety function.

- ▶ If damage or wear is found, the complete device must be replaced. Replacement of individual parts or assemblies is not permitted. The device may be repaired only by the manufacturer.
- ▶ Check the device for proper function at regular intervals and after every fault.

Inspection of the following is necessary to ensure trouble-free long-term operation:

- ▶ Correct switching function
- ▶ Damage, heavy contamination, dirt and wear
- ▶ Sealing of cable entry
- ▶ Loose cable connections or plug connectors.

**Information:** The year of manufacture can be seen in the bottom, right corner of the type label.

## Disposal

Pay attention to the applicable national regulations and laws during disposal.

## Declaration of conformity

The product complies with the requirements according to

- ▶ Machinery Directive 2006/42/EC
- ▶ Machinery Regulation (EU) 2023/1230 (from January 20, 2027)

The EU declaration of conformity can be found at [www.euchner.com](http://www.euchner.com). Enter the order number of your device in the search box. The document is available under *Downloads*.

## Service

If servicing is required, please contact:

EUCHNER GmbH + Co. KG  
Kohlhammerstraße 16  
70771 Leinfelden-Echterdingen  
Germany

### Service telephone:

+49 711 7597-500

### E-mail:

[support@euchner.de](mailto:support@euchner.de)

### Internet:

[www.euchner.com](http://www.euchner.com)

## Technical data

Parameter	Value
Housing material	Plastic
Degree of protection	
ZSA2A, ZSA2B	IP67
ZSR, ZSA1-1, ZSA1-2, ZSA1-3, ZSA2-1, ZSA2-2, ZSA2-4	IP65
Mechanical life, min.	1x10 <sup>6</sup> cycles
Ambient temperature	-5 ... +50 °C
Switching elements	see Fig. 1
Switching principle	Slow-action contact element
Switching current, min., at 24 V	1 mA
Switching voltage, min., at 10 mA	12 V
Conditional short-circuit current	100 A
<b>Characteristics acc. to EN ISO 13849-1</b>	
B <sub>10D</sub> at DC13 400 mA/24 V	3.9 x 10 <sup>5</sup>

Type	ZSA1-1/ZSA1-2 ZSA1-3 ZSA2-1/ZSA2-2 ZSA2-4	ZSA1A2... ZSA2A1... ZSA2A2... ZSR2A1... ZSR2A2...	ZSA2B2... ZSR2B2...	ZSA2A3... ZSA2A4... ZSA2B4... ZSR2A4...	ZSA2A2G...C	ZSA2B2...B	ZSA2B4...B
Connection	Tab connector 2.8 x 0.8 mm Acc. to IEC 760	Connecting cable	Connecting cable	Connecting cable	Plug connector 12-pin	Plug connector 7-pin	Plug connector 7-pin
Degree of contamination (external, acc. to EN 60947-1)	3	3	3	3	2	3	3
Connecting cable	for Ø3.5 ... 8.0 mm, screw connection via Skintop BS9	6 x 0.34 mm <sup>2</sup>	3 x 0.75 mm <sup>2</sup>	8 x 0.34 mm <sup>2</sup>	8 x 0.34 mm <sup>2</sup>	3 x 0.75 mm <sup>2</sup>	8 x 0.34 mm <sup>2</sup>
Cable length, max.	-	25 m	20 m	25 m	25 m	20 m	25 m
Rated impulse withstand voltage U <sub>imp</sub>	2.5 kV	2.5 kV	2.5 kV	2.5 kV	0.8 kV	0.8 kV	0.8 kV
Rated insulation voltage U <sub>i</sub>	250 V	250 V	250 V	250 V	32 V	32 V	32 V
Utilization category Acc. to EN 60947-5-1	AC-15 4 A 230 V DC-13 3 A 24 V	AC-15 2 A 230 V DC-13 2 A 24 V	AC-15 4 A 230 V DC-13 3 A 24 V	AC-15 2 A 230 V DC-13 2 A 24 V	AC-15 2 A 24 V DC-13 2 A 24 V	AC-15 4 A 24 V DC-13 3 A 24 V	AC-15 2 A 24 V DC-13 2 A 24 V
Short circuit protection at 24 V <sup>1)</sup>	4 A gG	2 A gG	4 A gG	2 A gG	2 A gG	4 A gG	2 A gG
Overvoltage category acc. to IEC EN 60664-1	2	2	2	2	2	2	2

1) In case of operating voltages other than DC 24 V, the short circuit protection must be dimensioned accordingly and checked.

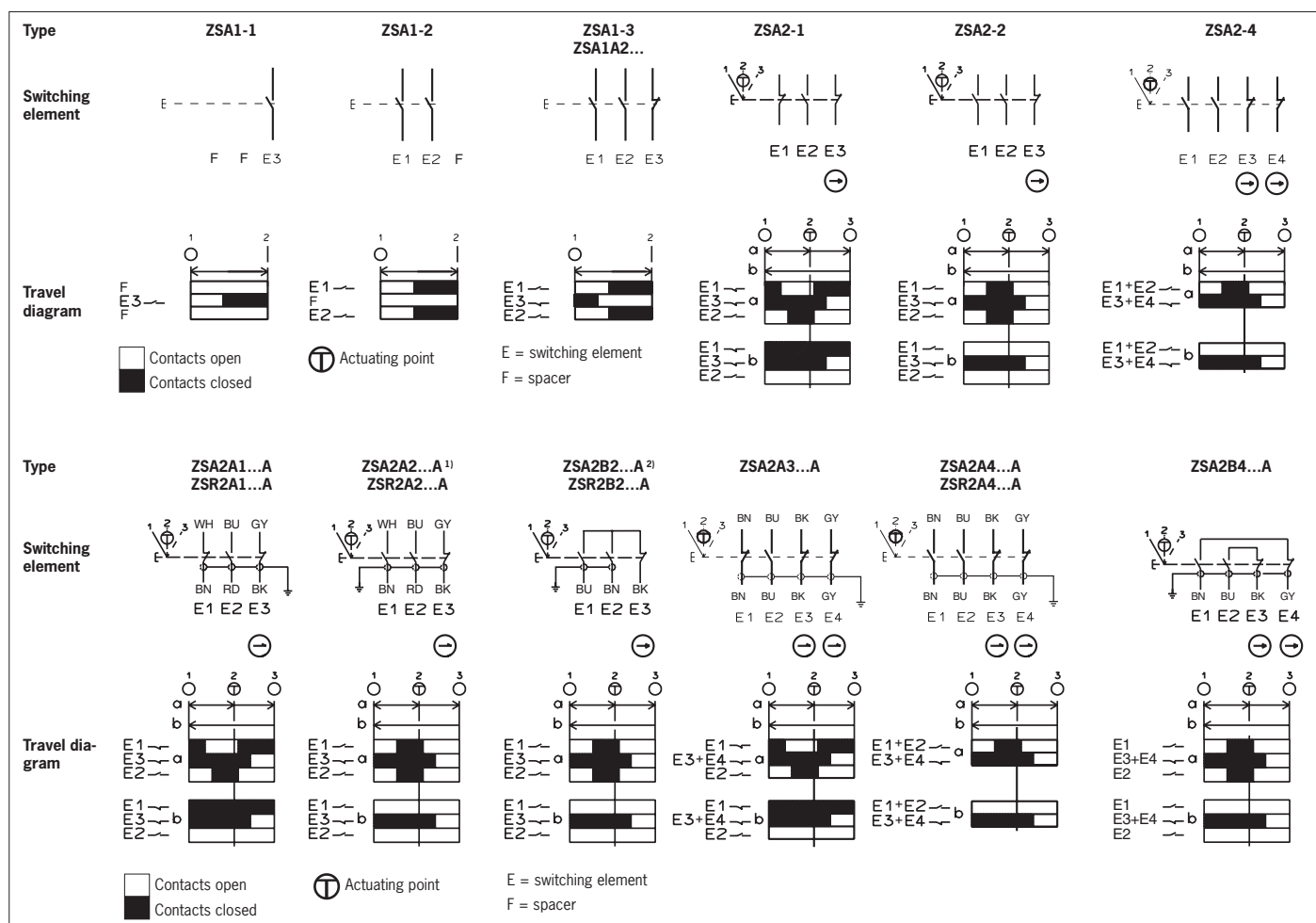

Fig. 1: Function of the switching elements (only for ZSA/ZSR with flying lead; see data sheet for plug)

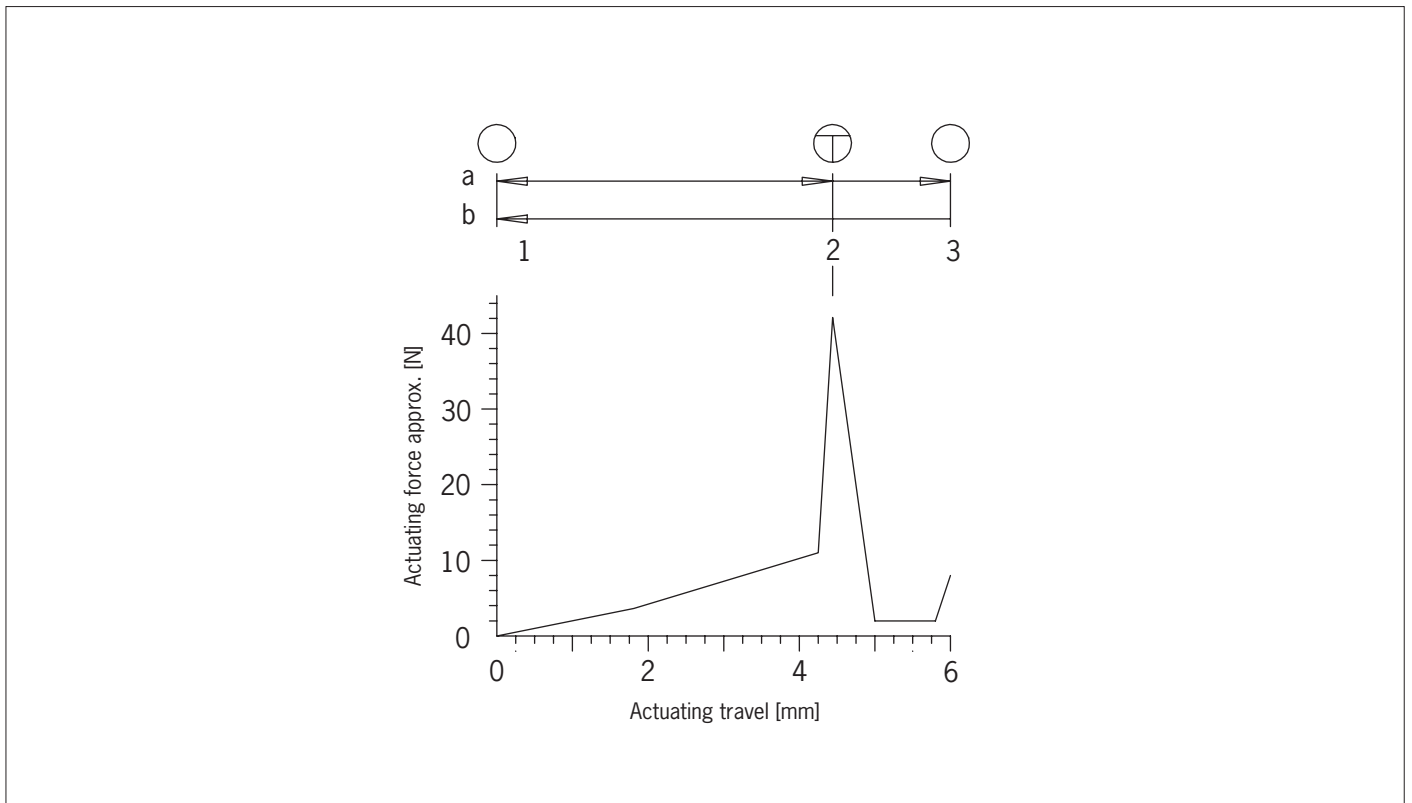

Fig. 4: Diagram of actuating force as a function of actuating travel

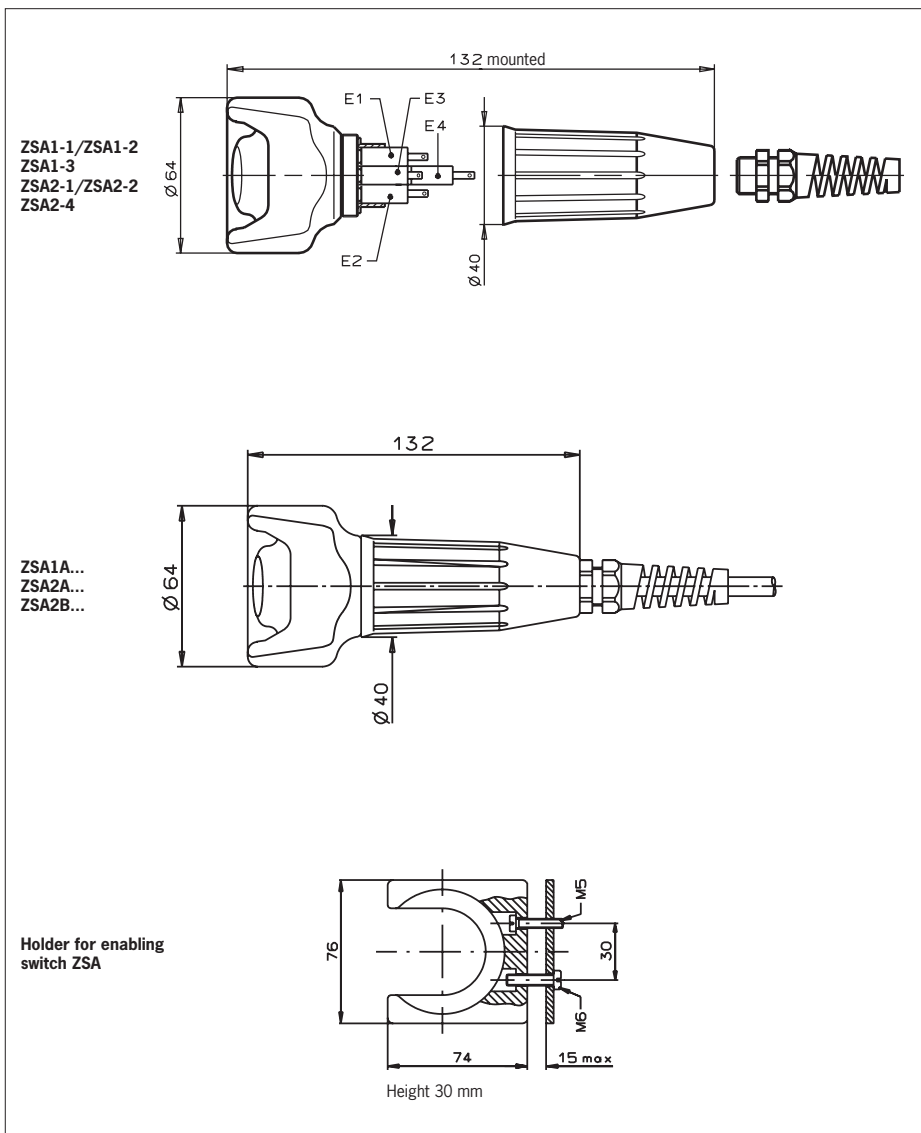

Fig. 2: Dimension drawing for enabling switch ZSA and holder for enabling switch ZSA

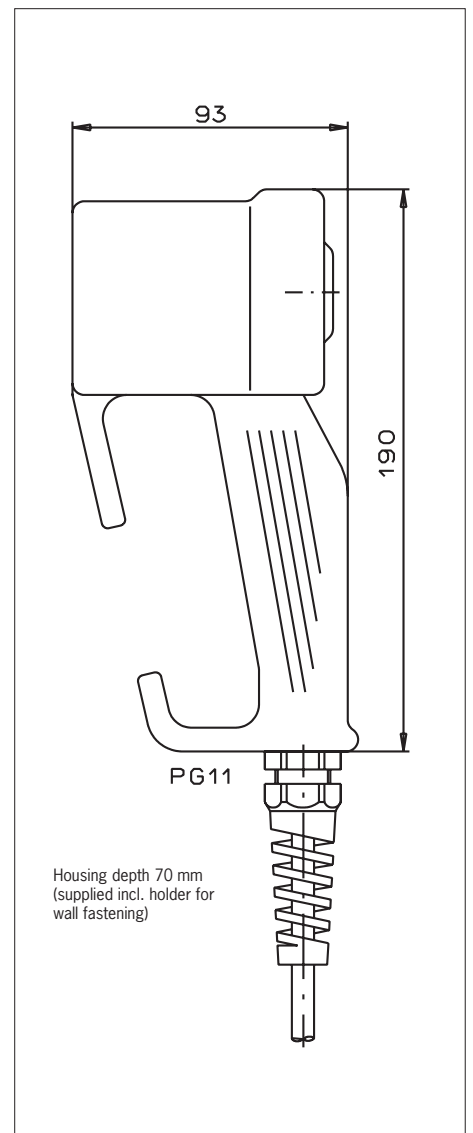

Fig. 3: Dimension drawing for enabling switch ZSR